



Construction Guidelines and How to Measure

For Private Label Vendors

1/8/2015

Table of Contents

Construction standards for TravelSmith Garments

Needles.....	4
Fabrics.....	4
Threads	4
Seams	4
Hems	5
Interlinings/Interfacings	5
Facings	5
Lining	5
Pockets	6
Waistbands	6
Zippers	7
Snaps, Hooks and Eyes and Hook and Loop Fasteners	8
Cuffs and Collars	8
Under-stitching	8
Top Stitch and Edge Stitch	8
Buttons	9
Buttonholes	10
Sweaters	10
Pressing and Finishing	10
Finishing	11
Labels and Tags	11
SPI Recommendations	
Woven Garments	12
Knit Garments	13

Points of Measure (POM)

How to measure

Match code in POM column in tech pack with POM code on measuring guide. Follow written instructions and illustrations for correct measurement method.

Bottoms14 - 38

Tops38 - 70

Construction Standards for TravelSmith Garments

All information is general. Tech pack will have specific information.

Needles

- Knits must be sewn with ball point needles
- Wovens must be sewn with sharp point needles
- Leather and vinyl must be sewn with a wedge point needle
- Correct needle size for the material must be used.
- No excess needle holes in completed garments are allowed
- All finished garments must be checked for broken needles.

Fabrics

- First quality fabrics must be used – no seconds
- Each lot must be cut from only one shade of the fabric, same grain direction and pattern; related separates must all be the same shade with the same color name. TravelSmith cannot sort by dye lot in the warehouse.
- Fabric must be inspected before cutting. Please forward fabric inspection report to TravelSmith.

Threads

- No monofilament thread
- Thread must match garment and trims unless specified as contrast
- Use polycore thread unless otherwise instructed.

Seams

- Seam slippage, ruptured or popping seams are not acceptable.
- Sewing tension must be adjusted properly for each fabric type. No skipped stitches, broken stitches, tangles or knots.
- Seam allowances should be even in width.
 - Crossed seams should be trimmed to reduce bulk.
 - Curved seams should be notched to lay flat.
 - Enclosed seams should be trimmed to reduce bulk.
 - Seams should be pressed open or to one side.
- All seams must be finished and secured. No loose threads.
- Knits must have stay tape at shoulders such as Mobilon or similar clear stay tape. Sweaters must have self knit or stay tape at shoulders.
- For knit seams, use at least a 4-thread mock safety stitch.
- For woven seams, use a 5-thread safety stitch seam
- For sheer fabrics, use French seams, mock French or flat-felled seams as indicated in the tech pack. Seams must pass seam slippage/seam strength testing.
- Rises and sleeve insertion seams should be sewn “on the round”.
- Pleat/Vent tacking: If a style has pleats or vents at the bottom opening or hem, they must be tacked in place prior to shipping.

- Hand tack pleat or vent in place with an X stitch ¼" high. Position is 1/8" up from edge and 1/8" from fold.
- For Men's shirting, use flat-felled seams.
- For Men's Sport coats, center back seam must be pressed open.

Hems

- Blind hem should not be visible on the outside of the garment. Stitches and tension should be adjusted properly. Raw edge of hem must be finished. Raw edge finish is determined by fabric type and weight. Please confirm finish with Tech Dept.
- Blind hem stitching should follow SPI Chart, unless specified. Be sure to secure beginning and end of stitching so hem does not come out.
- Sleeves and bottom hems must be hemmed "on the round".
- Stitched hems –Wovens – clean finish any shirt tail or straight hems by turning in the raw edge and stitching or as indicated in the tech pack.
- Stitched hems – Knits – use cover stitch in width indicated in tech pack. Cover stitch must cover raw edges. For single needle clean finish, turn in edge and stitch. Perl edge is also an acceptable finish for knits. Refer to tech pack for correct finish to use.
- Hems should be lie flat, no roping.

Interlinings/Interfacings

- Use compatible fusible interlinings in weight and glue melting temperature with fabric, making sure heat attachment requirement does not damage the garment fabric.
- Fusible interlinings must not have bubbles or come loose, especially after washing or dry cleaning
- Fusible interlinings must not pill or disintegrate after washing or dry cleaning.
- Non fusible interlining may be used in some instances where fusible is not suitable. Please get approval of use from Production and Tech Depts.

Facings

- Facings must lie flat without pulling or strain.
- Facing edges must be clean finished .
- Facing width must be at least 3" wide at hem and allow for turn over without edges showing at neckline.
- Facings must have Interlining/Interfacing. See above for instructions.

Lining

- Lining fabric must be opaque to prevent show-through of construction details.
- Lining fabric must withstand garment care – similar shrinkage rates within acceptable tolerance. Tolerance for differential shrinkage (between shell fabric and lining) is 2% maximum.
- Lining must fit smoothly inside garment, hanging straight without pulling with seams aligned with garment seams.
- Lining must have "ease" at CB seam, sleeve hem and at bottom hem. Lining hem must not hang below garment hem.
- Lining seams must be stitched securely and reinforced at stress points.

- Garment hems should be tacked at seams to prevent shifting of hem allowance and lining attached to raw edge. For jackets, lining should be tacked securely at underarm.
- For free hanging lining, hem garment and lining separately as per instructions in tech pack. Use French tacks to attach at seams. For outerwear, lining and garment can be attached using finished strips of fabric or other approved material.

Pockets

- Pockets must be uniform in size and shape.
- Pockets must be even horizontally unless otherwise indicated.
- Patch pockets -Top and Edge Stitches should be an equal distance from edge and each other. Beginning and ending stitches must be reinforced with a back stitch, bar tack or other reinforcement method indicated in the tech pack construction. Tack must not run off the pocket onto main garment piece.
- Side seam pockets – reinforce at top and bottom of pocket opening with a back stitch, bar tack, or other reinforcement method indicated in tech pack.
- Pocket bags should use durable fabric approved by Production.
- Welt Pockets should have even sized welts and follow the tech pack for placement and construction.

Waistbands

- Elastic – All elastic must be non roll and be attached to the waistband so it will not roll when being worn.
- Waistbands with fly front zippers or side zippers should have an inside button closure (clear button OK) and an outside closure.
- Waist self turn with 2 needle coverstitch $\frac{1}{4}$ " gauge create waistband. Fully cover raw edge at inside. Overlap coverstitch at ends by a minimum of 1". Must be circular sewn.

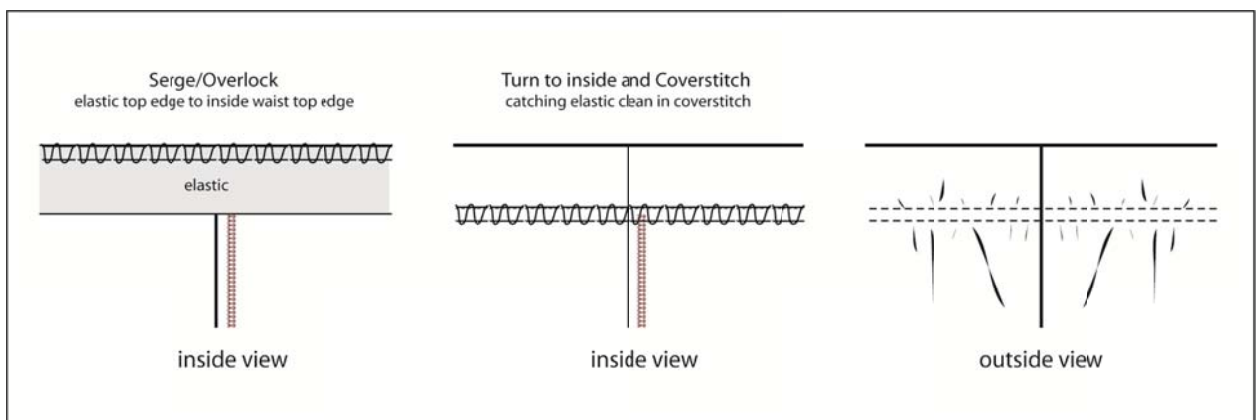

- Waist self turn and turn elastic with elastic. Multi-needle chainstitch to create waistband. If Back only sides are to be clean finished.

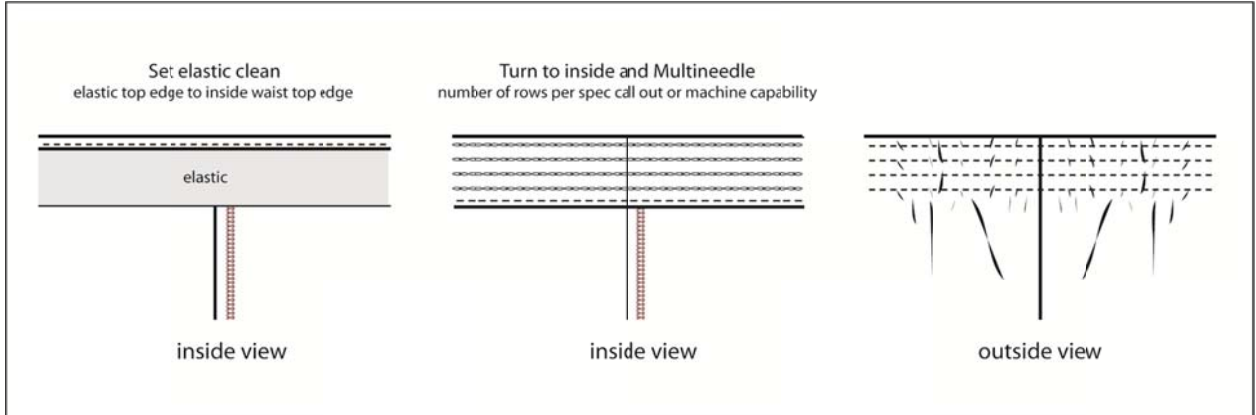

- One piece separate waistband, clean finish folder set with a single needle chainstitch, lockstitch or multi needle chainstitch as indicated on spec.

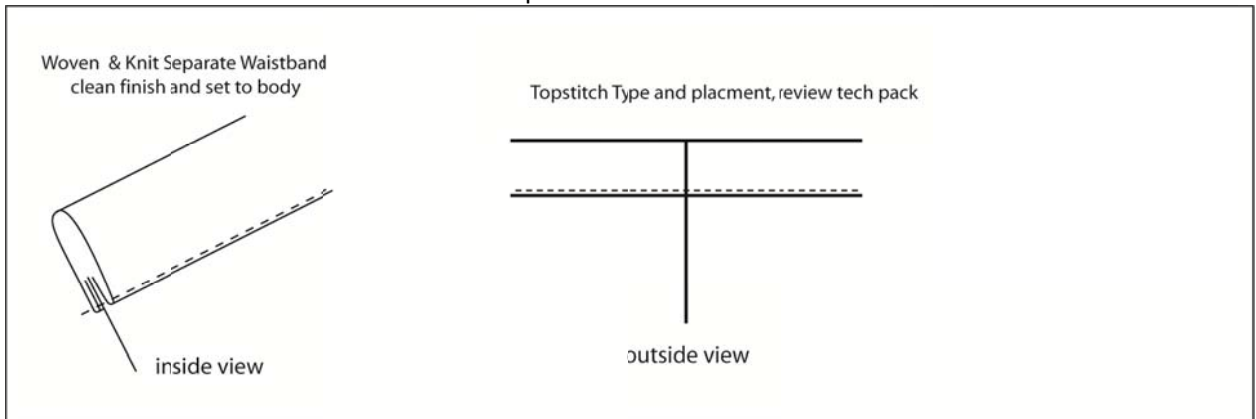

- One piece separate waistband, overlock raw edges then top stitch if specified on tech pack.

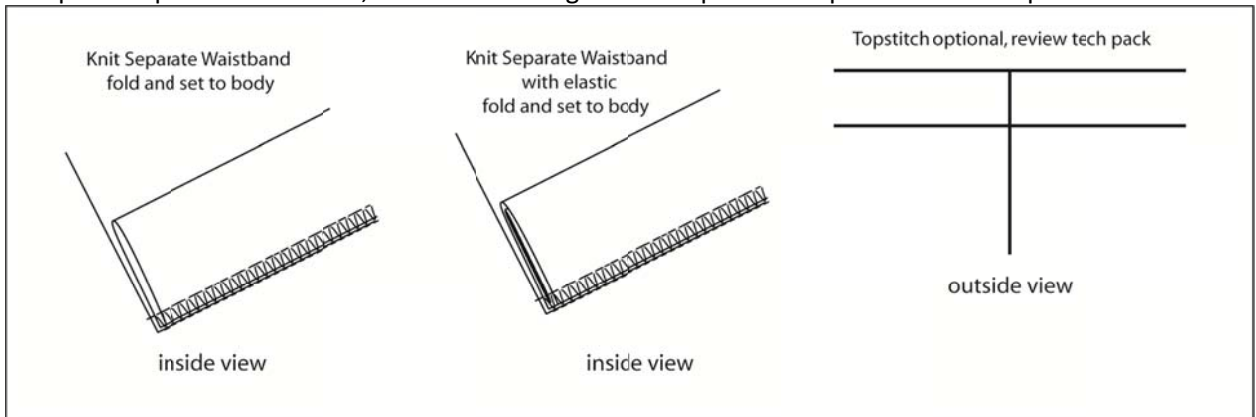

Zippers

- Use only YKK zippers for all production unless otherwise approved by merchants/production.
- Zipper tape must match garments main color unless otherwise specified. The color must be approved by merchants/production. All zipper tape must be pre-shrunk.
- All bottoms such as pants, shorts, skirts etc. must use locking zippers.

- Separating zippers: For Women's, zipper slider should be on wearer's left. For Men's, zipper slider should be on wearer's right.
- For bottoms, space from the top of the zipper to waist should not be more than ¼".
- For tops, follow tech pack with instructions of how far from bottom and top opening the zipper should be.
- Zipper insertion should be smooth, no roping on garment or binding. Zippers must lay flat.
- No sharp points or unfinished edges on zipper teeth. Zipper stops must be secured so slider does not come off.
- Backstitch the bottom of all zippers. Bar tack only if indicated in the tech pack.
- All zippers with metal teeth should have a zipper guard unless otherwise specified in the tech pack.

Snaps, Hooks and Eyes, and Hook and Loop Fasteners

- Always reinforce placement with interlining/interfacing if less than 3 layers of fabric.
- Snaps must be applied properly, must withstand pull test of 15lbs/10 seconds.
- Place fasteners at least 1/8" from edge of garment or as indicated in the tech pack.
- Snap set must be aligned with correct placement of the two parts.
- Hooks and eyes must be applied with small, neat stitches that do not show on the right side of garment.
- Hook and eye closures must be securely attached by small stitches or by attachment method for closure.
- Hook and Loop Tape (Velcro®)- Loop side must be placed on the body/bottom and the hook side must be on the toplayer unless otherwise specified, i.e. pocket flaps.
- All hook and loop tape that is rectangular or square must be rounded at the corners to avoid sharp edges. Corners can be die cut or hand cut.

Cuffs and Collars

- Use appropriate interfacing for collar and cuffs to maintain shape.
- Collar shape must be symmetrical on left and right.
- Collar must roll over smoothly or lie flat according to design.
- Only top collar should be visible. Under collar should not show. Collar should cover neck seam unless otherwise indicated in tech pack.
- Cuffs should be even in width.
- For two-piece cuff, the seams should be on the edge of the cuff.
- Cuffs and collars must be "clean-finished" with a single or double needle top stitch. No serged edge on the cuff, collar or collar band.

Under-stitching

- Use under-stitching to keep facings from rolling out for necklines, collars, cuffs or pocket linings.
- Should never be visible on outside of garment.
- Thread color should match fabric.

Top Stitch and Edge Stitch

- Top Stitches must be evenly stitched; see SPI specified on chart.
- Double needle Top Stitch must be a uniform width between needles in all garment areas.

- Adjust tension to avoid puckering in Top Stitched areas.

Buttons

- 2-hole buttons must be lock stitched to prevent them from falling off.



- 4-hole buttons must be cross stitched and lock stitched.



- Shank buttons for outerwear must be reinforced with a small button on the facing side. Thread must be secured with a whip stitch, not half stitches. If outside button does not have a shank, it must have a thread shank.

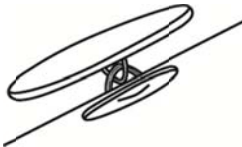

- For outerwear, a 2 or 4 hole button with thread shank should be used. Thread must be secured with a whipstitch, not half stitches. Button must have at least 6 loops of thread holding the button to the garment. Wind thread 2-3 times around thread loops.

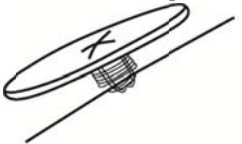

- Necked shank button without a reinforcement button must have at least 6 loops of thread holding the button to the garment. Wind thread 2-3 times around thread loops (below shank) to neck button. Secure thread with a whipstitch. Do not pull thread too tightly so shank sinks into fabric.

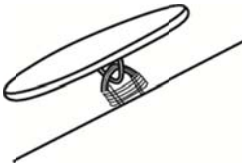

- Reversible styles with buttons must have thread shanks on each side. Buttons must be easy to fasten on both sides.

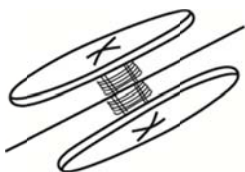

- 2 hole or 4 hole buttons with a button backer: Backer Button does not need a thread shank however outer button must have either a thread shank or must be easy to fasten.

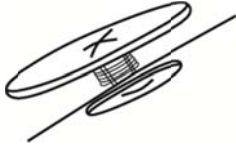

- Buttons must pass care label instructions and must not crack, chip, discolor, rust or melt.
- Buttons must pass lead in surface coating testing (16 CFR 1303) at >90 ppm.
- Must pass button pull test.

Buttonholes

- Buttonholes should be constructed with a top and bottom feed lockstitch sewing machine. See SPI for buttonholes on chart. Tension should be properly adjusted.
- For women's garments, buttonholes are on wearer's right unless otherwise specified.
- For men's garments, buttonholes are on wearer's left.
- Overlap should be wide enough to cover without a gap.
- The length of the buttonhole should be at least 1/8" longer than the length of the button plus button thickness.
- Buttonhole stitch width must be wide enough to not pull away from cut edge of fabric. Extra reinforcement must be used under buttonholes if fabric is very light weight or loosely woven. Use appropriate quality and color.
- For keyhole buttonholes, the tail on the keyhole must be short, neat and clean.
- To finish buttonhole, first neatly cut it open, then trim all fabric and threads closely. No loose threads are allowed.

Sweaters

- Float length should be no longer than 1".
- Seams must stretch to maximum stretch of knit panels/fabric without breaking.
- Side vents must be clean finished with tubular, rib knit, hand crochet or self start. Tech pack will confirm preference.
- Beads or sequins must be knotted after every fifth bead.
- Shoulder seams must have self knit or stay tape.
- All internal seams except for shoulder must be linked except where specified otherwise.
- Linking tension should be the same on all seams within a garment.
- Linked seams must stretch to the maximum stretch of knit panels without breaking.
- Necklines with tubular or rib trim should have closing seam placed at HPS on wearer's right.
- Closed necklines should meet minimum stretch requirements without breaking stitches.
- Sweater starts on neck, sleeve, and bottom opening are ribbed, tubular, self start or self yarn crochet.
- Tighten tension 1/2" on all rib starts unless otherwise indicated.

Pressing and Finishing

During Construction:

- All woven side seams and inseams that are not top stitched should be pressed towards the back. No twisting of seams allowed.

- Press all dart seam allowances toward center of garment or towards hem.
- All pleat seam allowances to be pressed toward side seam or garment unless otherwise specified.

Finishing:

- Garment surface is smooth and free of wrinkles. No puckering of seams or other construction details.
- No overpressing or iron imprints.
- No shine, scorching or melting allowed.
- Inside construction details should not show on outside.
- No stretching or shrinking, no water marks or mineral spots allowed.
- Seams and darts are pressed smoothly on the stitching lines. Fabric can not fold over stitching line or look bubbled.

Labels and Tags

- All care labels must be sewn to the inside of garment as specified.
- Care labels and printing must last for the normal life of the garment.
- Care information must conform to Federal Trade Commission rulings and be legible and consistent with third party test reports and other hang tags.
- Fiber content wording cannot be abbreviated, must add up to 100% (with greatest percentage first), use generic names (not trade names) and conform to the Federal Trade commission rulings on labeling. <http://www.ftc.gov/os/statutes/textile/rr-textl.shtm>
- Fiber content must be consistent with third party test reports and any other hang tags.
- Any TravelSmith hang tags or labels as specified in the tech pack.
- All other relevant Federal Trade Commission labeling regulations must be followed.
- Any hang tags with claims must have scientific laboratory testing for validation. This includes all off-line buys.
- Website addresses and retail pricing should NOT be included on hang tags.

SPI Recommendations for Woven & Knits

Woven Garments

<u>Garments</u>	<u>SPI</u>	<u>Comments</u>	<u>Garments</u>	<u>SPI</u>	<u>Comments</u>
Denim Jeans, Jackets, Skirts	7 - 8	Fewer stitches per inch generally will give a more contrast stitch appearance.	Topstitch, Edgestitch	8 - 12	Usually 8 to 12 SPI is adequate to hold seams in place or use for decorative purposes. Adjust tension according to fabric and thickness.
Twill Pants or Shorts	8 - 10	More stitches per inch will help minimize seam grinning	Dresses, Skirts	10 - 12	Due to many of the operations being lockstitch, usually 10 - 12 SPI is required to provide adequate seam strength
Trousers, Dress Pants, Slacks	10 - 12	On some operations like serge panels, it may be desirable to use a longer stitch length	Blindstitch Operations on Slacks, Dresses, Skirts, etc.	3 - 5	A long stitch length is desirable to minimize the dimple of appearance of the needle penetration on the outside of the garment.
Dress Shirts or Blouses	14 - 20	Using more SPI allows the use of smaller diameter threads that will minimize seam puckering	Button sew (4 hole button)	16	Button sew machines are cycle machines with a predetermined number of stitches per cycle.
Casual Shirts, Blouses, Tops	10 - 14	Using more SPI will give more of a tailored stitch appearance and better seam coverage when serging	Buttonhole (1/2" purl or whip stitch)	85 - 90	Generally sewn vertically - approx. 85 - 90 stitches with a lockstitch buttonhole machine.

Knit Garments

<u>Garments</u>	<u>SPI</u>	<u>Comments</u>	-	<u>Garments</u>	<u>SPI</u>	<u>Comments</u>
Jersey T-shirts, Tops, Polos	10 - 12	Using more SPI increases the chance of needle cutting.		Swimwear, Intimates	12 - 16	The more elastic the seam, the more SPI that should be used to minimize stitch cracking.
Underwear	12 - 14	The more elastic the seam, the more SPI that should be used to minimize stitch cracking.		Dresses, Skirts	10 - 12	The more elastic the seam, the more SPI that should be used to minimize stitch cracking.
Fleece	10 - 12	More stitches per inch are required to provide the proper seam coverage on fleece.		Stretch Knits (Lycra®, Spandex, etc.)	14 - 18	More stitches per inch are required to provide the proper seam elasticity.
Sweaters (Med. To Hvy.)	8 - 10	The more elastic the seam, the more SPI that should be used to minimize stitch cracking.				

TRAVELSMITH OUTFITTERS: How To Measure

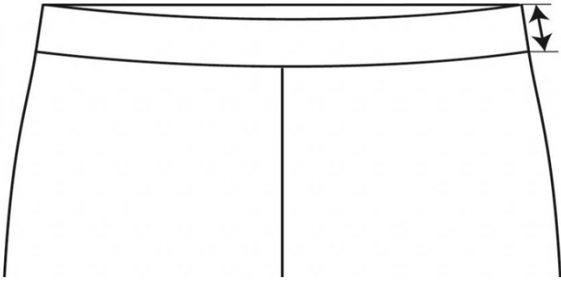
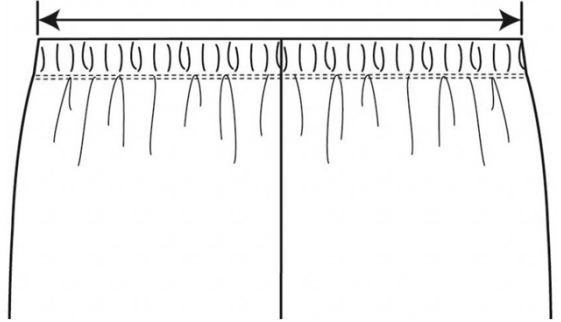
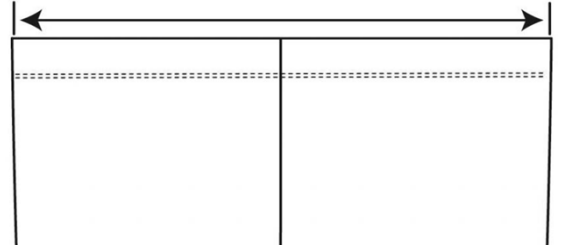
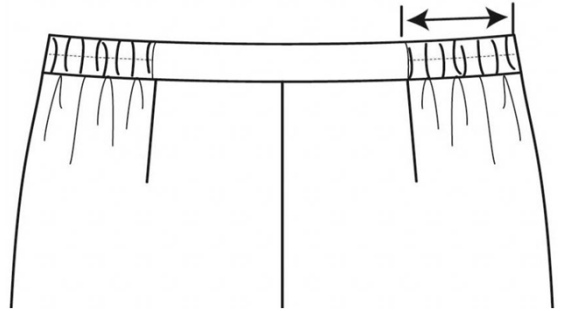
POM	Point of Measure	How To Measure Text	How To Measure Image
B170	Waistband Height	Measure Waistband Seam to Edge	
B171	Waist - Relaxed	<ul style="list-style-type: none"> • Line up front and back top edge of waistband evenly. • Measure straight across the waistband from inside edge to edge at the top of the waistband. 	
B172	Waist - Extended	<ul style="list-style-type: none"> • Line up front & back top edge of waistband evenly. • Measure from inside edge to edge with elastic fully extended with fabric flat. 	
B173	Side Waist Elastic - Relaxed	Measure from side seam to elastic seam at top of waist	

TRAVELSMITH OUTFITTERS: How To Measure

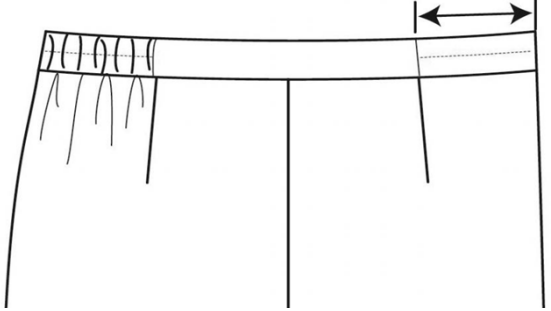
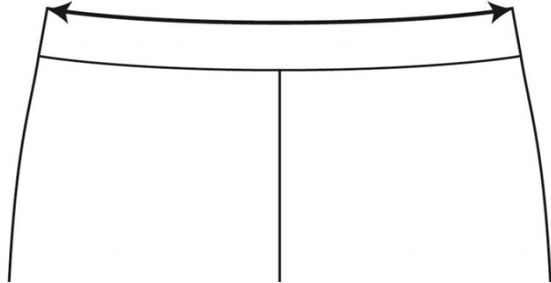
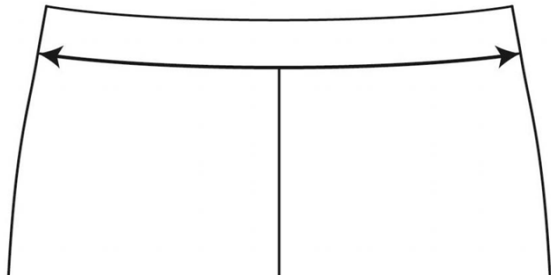
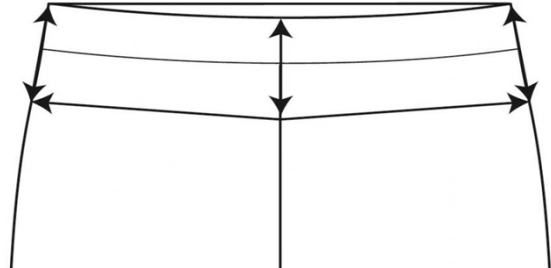
POM	Point of Measure	How To Measure Text	How To Measure Image
B174	Side Waist Elastic - Extended	Measure from side seam to elastic seam with elastic fully extended with fabric flat.	
B175	Contour Waist at Top Edge	Measure at the top edge of waistband along the curve.	
B176	Contour Waist at Waist Seam	Measure along the waist seam curve from edge to edge.	
B180	High Hip (3 Point) - (4") from Top Edge	<ul style="list-style-type: none"> • Lay garment flat with front of garment facing up. • Front waist may sit lower than back waist. • Measure down specified distance from the top edge at side edges and at center front. • Measure to each point, edge to edge. 	

TRAVELSMITH OUTFITTERS: How To Measure

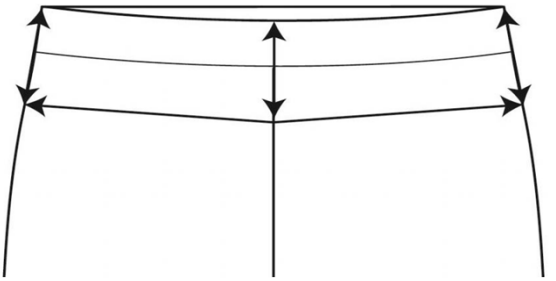
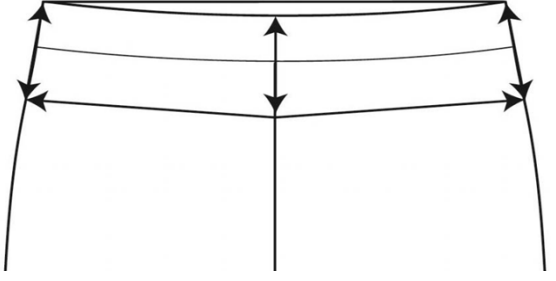
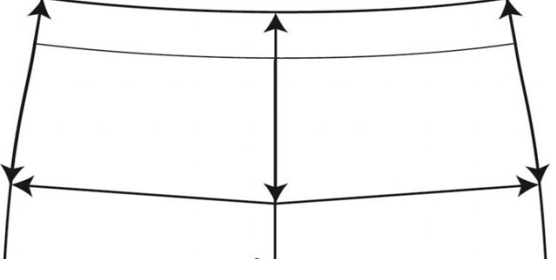
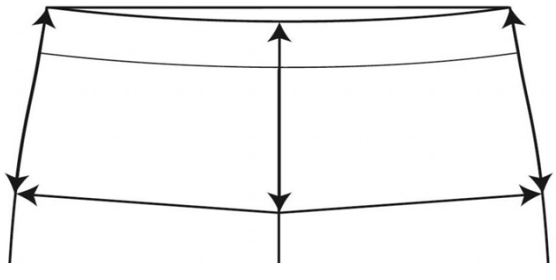
POM	Point of Measure	How To Measure Text	How To Measure Image
B181	High Hip (3 Point) - Petite (3 3/4") from Top Edge	<ul style="list-style-type: none"> • Lay garment flat with front of garment facing up. • Front waist may sit lower than back waist. • Measure down specified distance from the top edge at side edges and at center front. • Measure to each point, edge to edge. 	
B182	High Hip (3 Point) - Plus (4 1/2") from Top Edge	<ul style="list-style-type: none"> • Lay garment flat with front of garment facing up. • Front waist may sit lower than back waist. • Measure down specified distance from the top edge at side edges and at center front. • Measure across these 3 points, edge to edge. 	
B185	Low Hip (3 Point) - (8") from Top edge	<ul style="list-style-type: none"> • Lay garment flat with front of garment facing up. • Front waist may sit lower than back waist. Close pleats. • Measure down specified distance from the bottom of the waistband at side edges and at center front. • Measure across these 3 points, edge to edge. 	
B186	Low Hip (3 Point) - Petite (7 1/2") from Top edge	<ul style="list-style-type: none"> • Lay garment flat with front of garment facing up. • Front waist may sit lower than back waist. Close pleats. • Measure down specified distance from the bottom of the waistband at side edges and at center front. • Measure to each point, edge to edge. 	

TRAVELSMITH OUTFITTERS: How To Measure

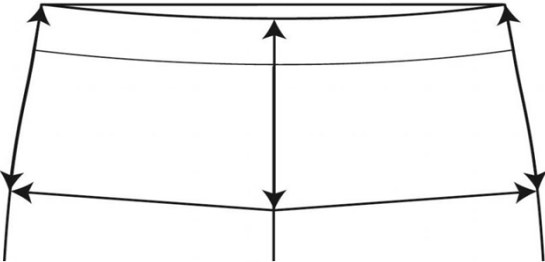
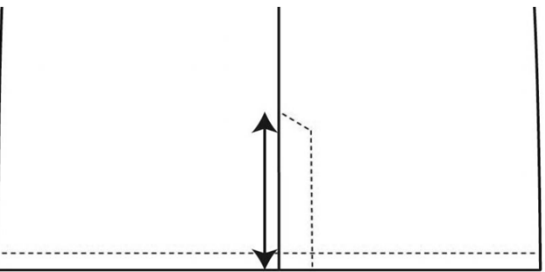
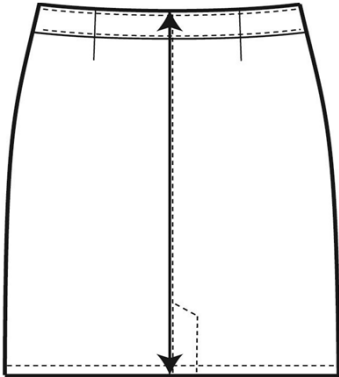
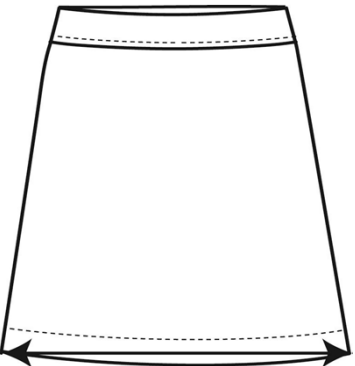
POM	Point of Measure	How To Measure Text	How To Measure Image
B187	Low Hip (3 Point) - Plus (9") from Top edge	<ul style="list-style-type: none"> • Lay garment flat with front of garment facing up. • Front waist may sit lower than back waist. Close pleats. • Measure down specified distance from the bottom of the waistband at side edges and at center front. • Measure to each point, edge to edge. 	
B199	Vent Height from hem	Measure vent from the top edge of the opening to the bottom hem.	
B325	Center Back Length - From Top Edge (skirts)	At center back, measure from the top edge to bottom hem.	
B331	Sweep - Straight Edge to Edge - (skirts)	Measure straight across the bottom from edge to edge.	

TRAVELSMITH OUTFITTERS: How To Measure

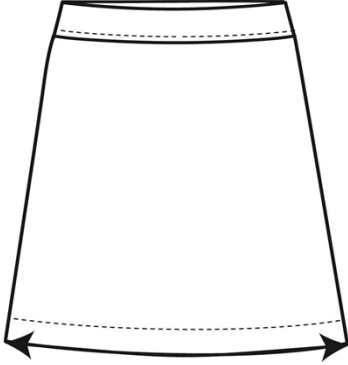
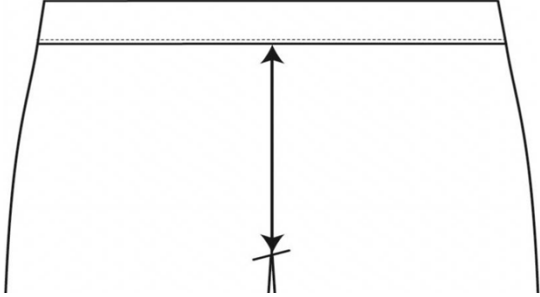
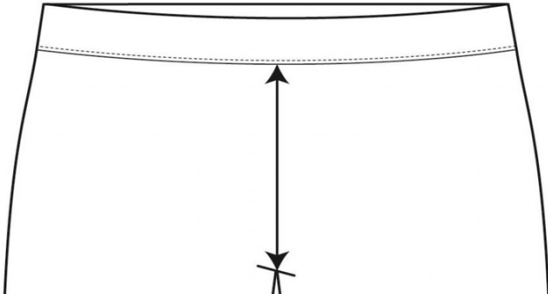
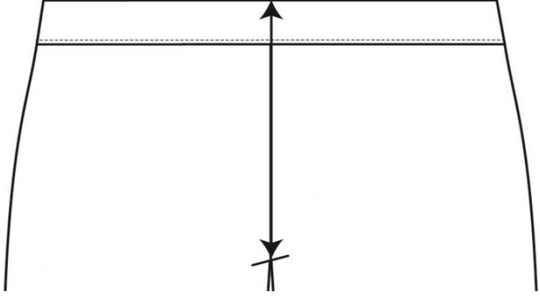
POM	Point of Measure	How To Measure Text	How To Measure Image
B332	Sweep - Along Contour - (skirts)	Measure along the contour of the hem, from edge to edge.	
B348	Back Rise - from waist seam	Following the contour of the back rise seam, measure from the crotch intersection to the waist seam.	
B349	Front Rise - from waist seam	Following the contour of the front rise seam, measure from the crotch intersection to the waist seam.	
B350	Back Rise - from Top Edge	Following the contour of the back rise seam, measure from the crotch intersection to the top of the waistband.	

TRAVELSMITH OUTFITTERS: How To Measure

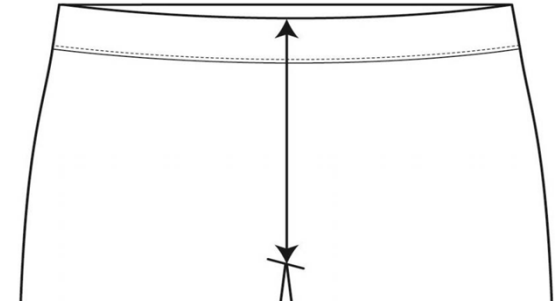
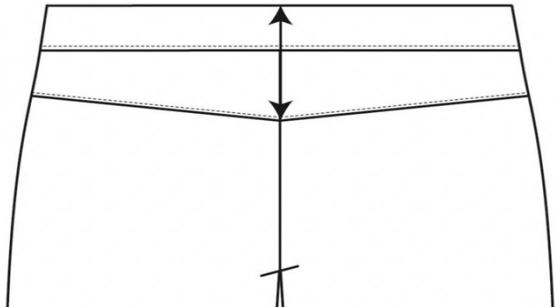
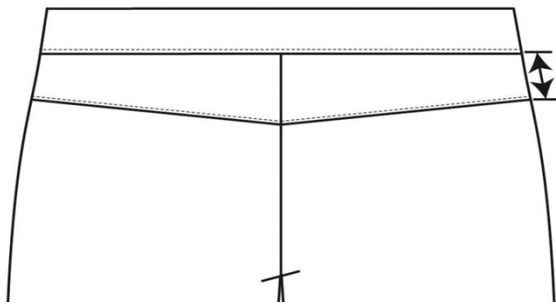
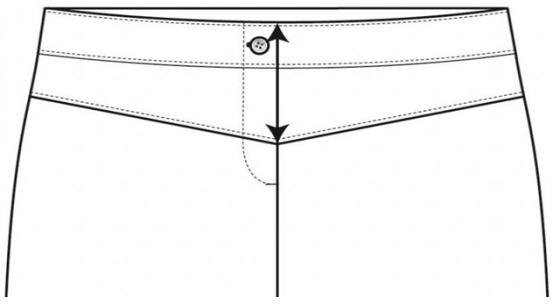
POM	Point of Measure	How To Measure Text	How To Measure Image
B351	Front Rise - from Top Edge	Following the contour of the front rise seam, measure from the crotch intersection to the top of the waistband.	 <p>The diagram shows a front view of a pair of pants. A vertical double-headed arrow indicates the measurement from the crotch intersection point up to the top edge of the waistband.</p>
B352	Back Yoke Height @ CB	Measure from yoke seam to waist seam at center back.	 <p>The diagram shows a back view of a pair of pants. A vertical double-headed arrow indicates the measurement from the waist seam down to the yoke seam at the center back.</p>
B353	Back Yoke Height @ SS	Measure from yoke seam to waist seam at side seam.	 <p>The diagram shows a back view of a pair of pants. A vertical double-headed arrow indicates the measurement from the waist seam down to the yoke seam at the side seam.</p>
B355	Front Yoke Height @ CF - Bottoms	Measure from yoke seam to waist seam at center front	 <p>The diagram shows a front view of a pair of pants. A vertical double-headed arrow indicates the measurement from the waist seam down to the yoke seam at the center front.</p>

TRAVELSMITH OUTFITTERS: How To Measure

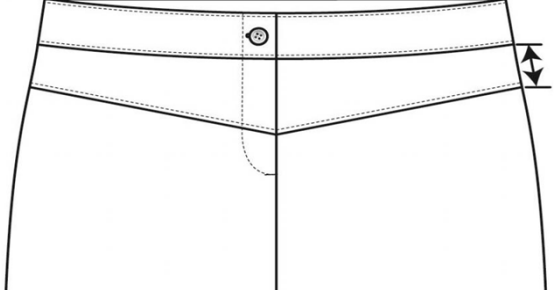
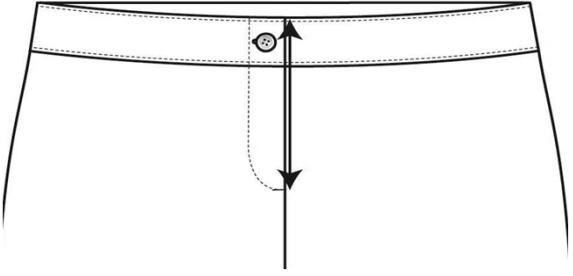
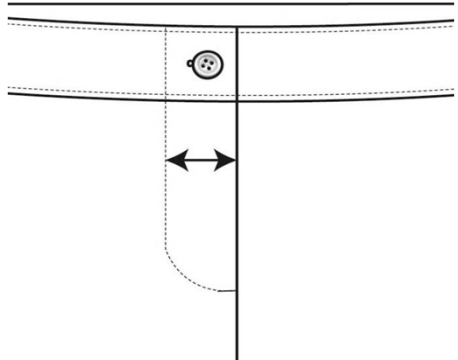
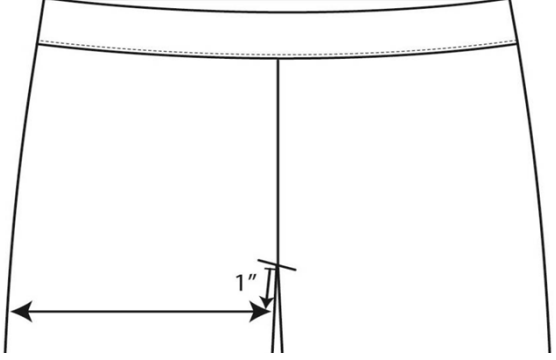
POM	Point of Measure	How To Measure Text	How To Measure Image
B356	Front Yoke Height @ SS	Measure from yoke seam to waist seam at side seam.	
B358	Fly Length	Measure from top of waist edge to bottom of J-Stitch.	
B359	Fly Width	Measure from fly edge to outside stitch line.	
B360	Thigh - 1" Below Crotch	On the front, 1" below the crotch, measure straight across the thigh from edge to edge, perpendicular to the grain of the fabric.	

TRAVELSMITH OUTFITTERS: How To Measure

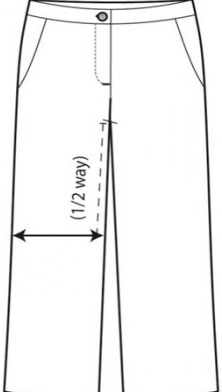
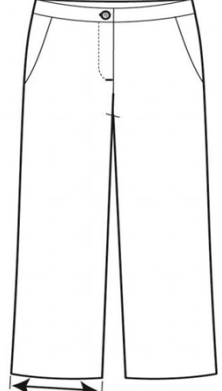
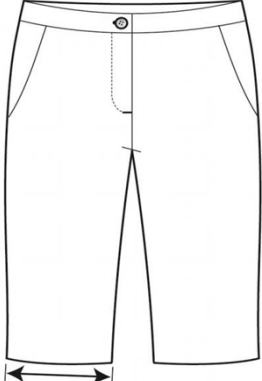
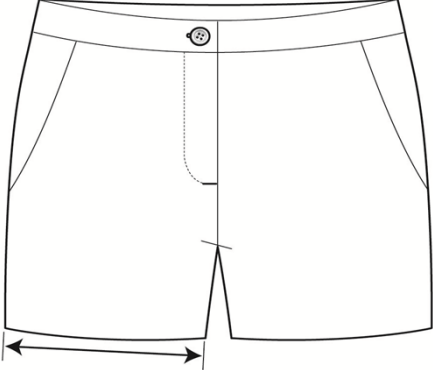
POM	Point of Measure	How To Measure Text	How To Measure Image
B361	Knee - at 1/2 of Inseam	At midpoint of inseam measure straight across the knee from edge to edge, perpendicular to the grain of the fabric.	
B370	Leg Opening (Pants)	Measure straight across the leg opening from edge to edge.	
B371	Leg Opening (Capris/Crop)	Measure straight across the leg opening from edge to edge.	
B372	Leg Opening (Shorts)	Measure straight across the leg opening from edge to edge.	

TRAVELSMITH OUTFITTERS: How To Measure

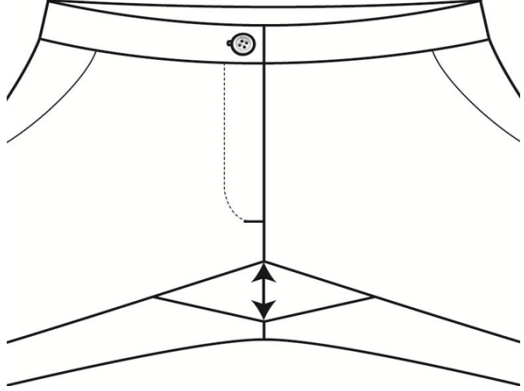
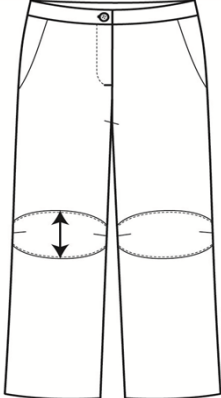
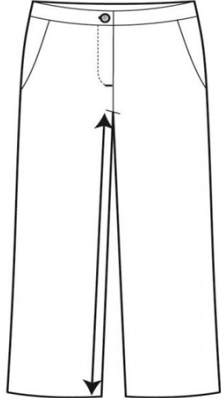
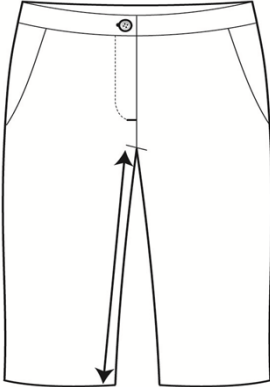
POM	Point of Measure	How To Measure Text	How To Measure Image
B375	Gusset Width at Crotch - Bottoms		
B376	Gusset Height at Knee - Bottoms		
B390	Inseam (pants)	Measure from crotch intersection point to bottom opening.	
B391	Inseam (Capris/Crop)	Measure from crotch intersection point to bottom opening.	

TRAVELSMITH OUTFITTERS: How To Measure

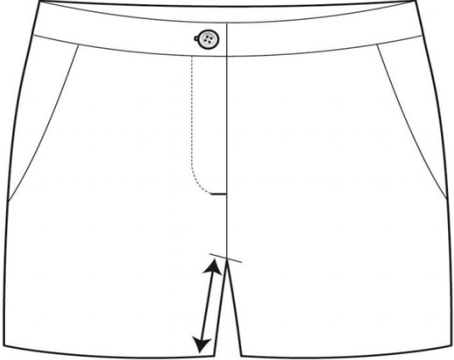
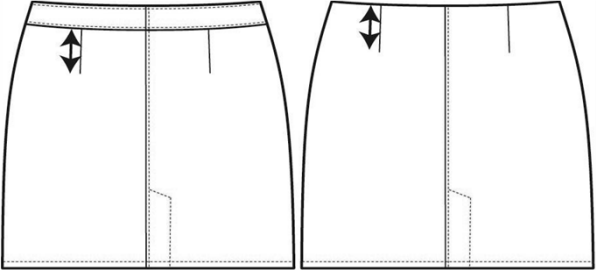
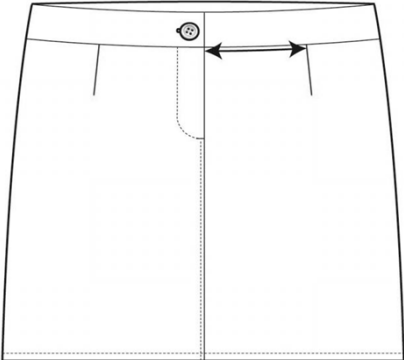
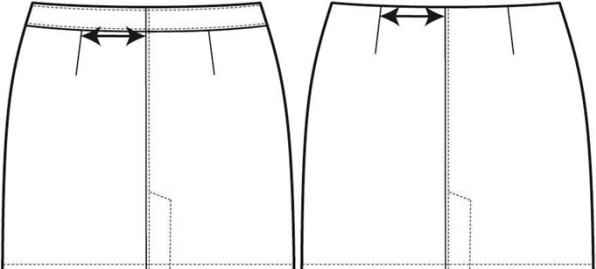
POM	Point of Measure	How To Measure Text	How To Measure Image
B392	Inseam (shorts)	Measure from crotch intersection point to bottom opening.	
B393	Dart Length	Measure from the bottom of the dart to the waist seam.	
B394	Dart Placement From CF	Measure along waist from dart to center front seam.	
B395	Dart Placement From CB	Measure along waist from dart to center back seam.	

TRAVELSMITH OUTFITTERS: How To Measure

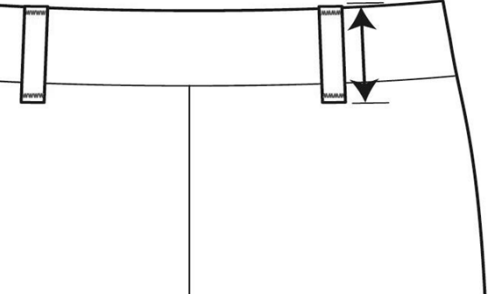
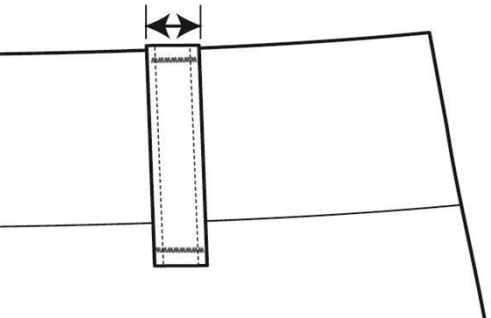
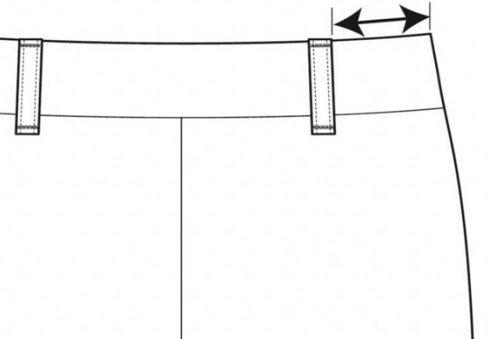
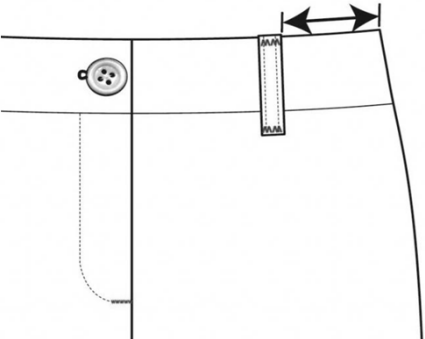
POM	Point of Measure	How To Measure Text	How To Measure Image
B400	Belt Loop Length	Measure belt loop length edge to edge.	
B401	Belt Loop Width	Measure belt loop width edge to edge.	
B406	Belt Loop Placement Back - From Side Seam at Waist	From side seam, measure along waist to the outer edge of belt loop.	
B407	Belt Loop Placement Front - From Side Seam at Waist	From the side seam, measure along waist to the outer edge of belt loop.	

TRAVELSMITH OUTFITTERS: How To Measure

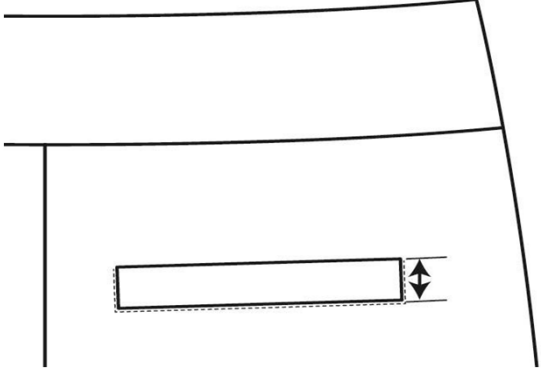
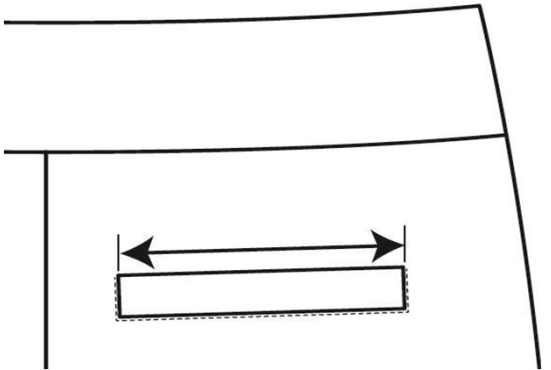
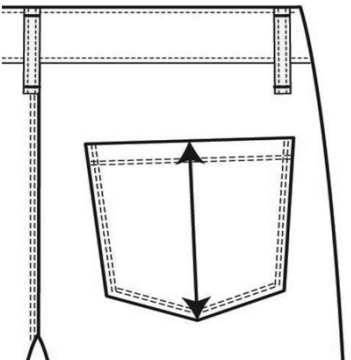
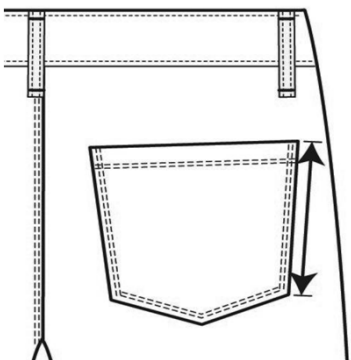
POM	Point of Measure	How To Measure Text	How To Measure Image
B408	Back Welt Pocket Height	Measure from top of welt to seam.	
B409	Back Welt Pocket Length	Measure from edge to edge at top of welt.	
B410	Back Pocket Height @ Center	25	
B411	Back Pocket Height @ Side	Measure at side edge of pocket from top edge to bottom.	

TRAVELSMITH OUTFITTERS: How To Measure

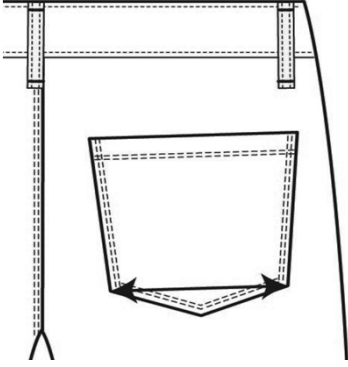
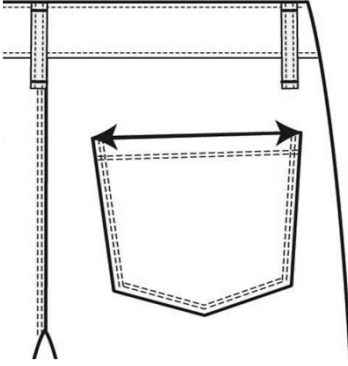
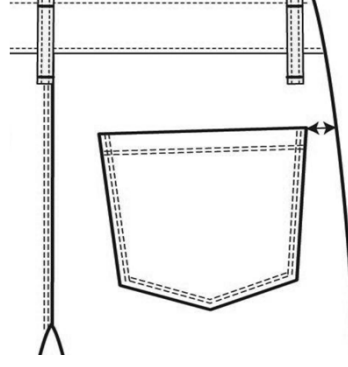
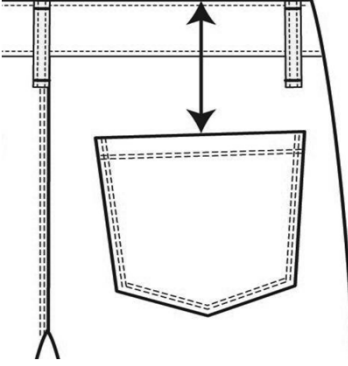
POM	Point of Measure	How To Measure Text	How To Measure Image
B412	Back Pocket Width @ Bottom	Measure straight across bottom of pocket from edge to edge.	
B413	Back Pocket Width @ Top	Measure straight across top of pocket from edge to edge.	
B414	Back Pocket Position From Sideseam	Measure straight from top edge of pocket to side seam.	
B415	Back Pocket Position From Top of Waist	Measure from top of waistband to top edge of pocket.	

TRAVELSMITH OUTFITTERS: How To Measure

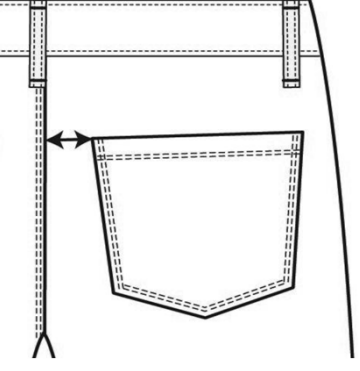
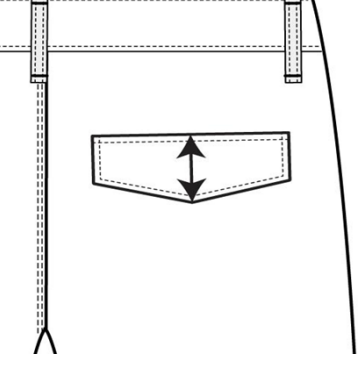
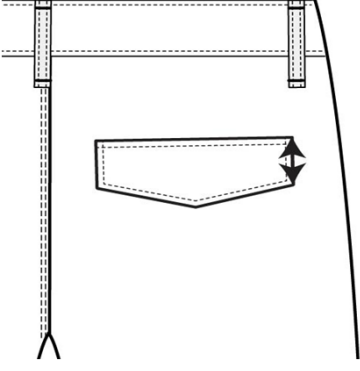
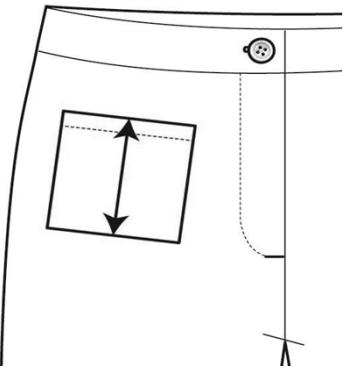
POM	Point of Measure	How To Measure Text	How To Measure Image
B416	Back Pocket Position From CB	Measure straight from top edge of pocket to center back seam.	
B417	Back Pocket Flap Height @ Center	Measure at center of pocket flap straight from top edge to bottom edge.	
B418	Back Pocket Flap Height @ Side	Measure at side edge of pocket flap straight from top edge to bottom edge.	
B420	Front Pocket Height @ Center	Measure center of pocket straight down from the top edge to the bottom edge.	

TRAVELSMITH OUTFITTERS: How To Measure

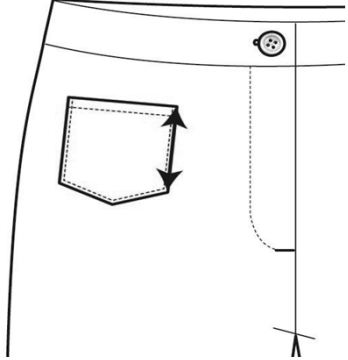
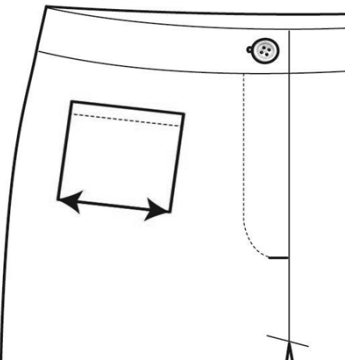
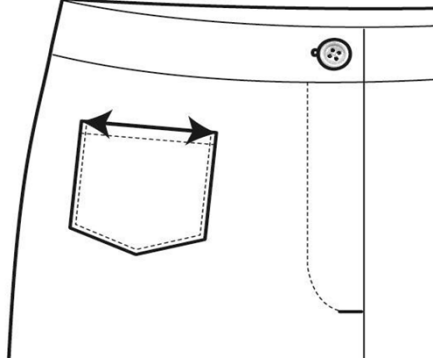
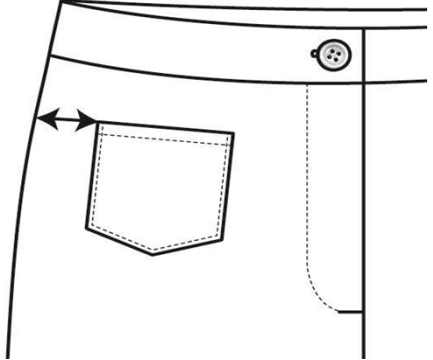
POM	Point of Measure	How To Measure Text	How To Measure Image
B421	Front Pocket Height @ Side	Measure side edge of pocket from the top edge to the bottom edge.	
B422	Front Pocket Width @ Bottom	Measure bottom of pocket straight across from edge to edge.	
B423	Front Pocket Width @ Top	Measure straight across top of pocket from edge to edge.	
B424	Front Pocket Position From Sideseam	Measure straight from top edge of pocket to side seam.	

TRAVELSMITH OUTFITTERS: How To Measure

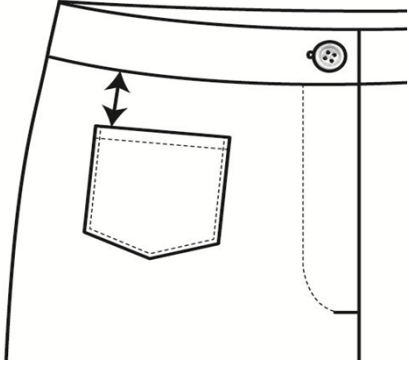
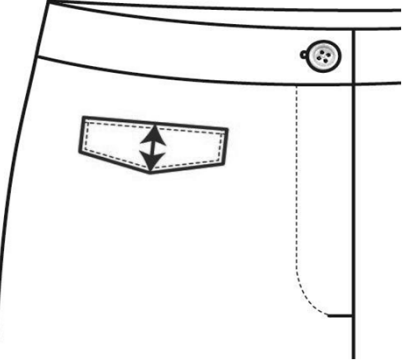
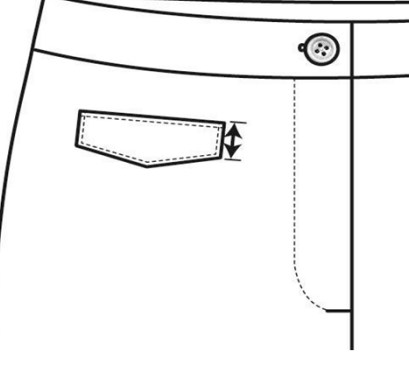
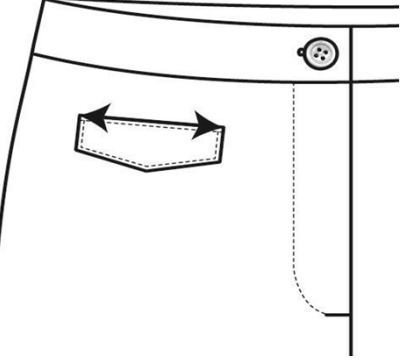
POM	Point of Measure	How To Measure Text	How To Measure Image
B425	Front Pocket Position From Waist	Measure from waist seam to top edge of pocket.	 <p>The diagram shows a side view of a pair of pants with a buttoned waistband. A vertical double-headed arrow indicates the distance from the waist seam to the top edge of the front pocket.</p>
B427	Front Pocket Flap Height @ Center	Measure at center of pocket flap straight from top edge to bottom edge.	 <p>The diagram shows a side view of a pair of pants with a buttoned waistband. A vertical double-headed arrow is positioned at the center of the pocket flap, measuring from its top edge to its bottom edge.</p>
B428	Front Pocket Flap Height @ Side	Measure at side edge of pocket flap straight from top edge to bottom edge.	 <p>The diagram shows a side view of a pair of pants with a buttoned waistband. A vertical double-headed arrow is positioned at the side edge of the pocket flap, measuring from its top edge to its bottom edge.</p>
B429	Front Pocket Flap Width	Measure straight across top of flap from edge to edge.	 <p>The diagram shows a side view of a pair of pants with a buttoned waistband. A horizontal double-headed arrow is positioned across the top edge of the pocket flap, measuring from one side edge to the other.</p>

TRAVELSMITH OUTFITTERS: How To Measure

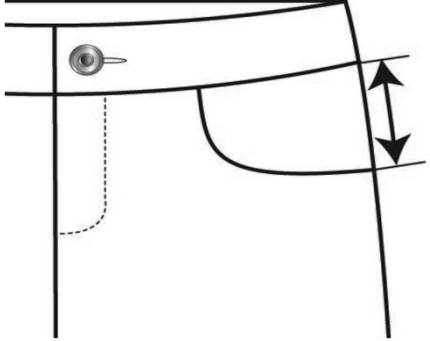
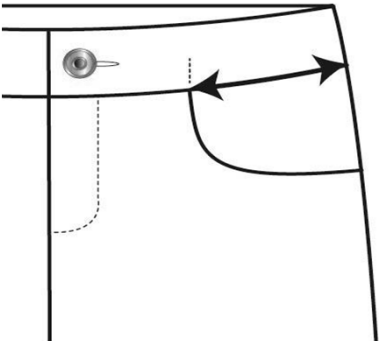
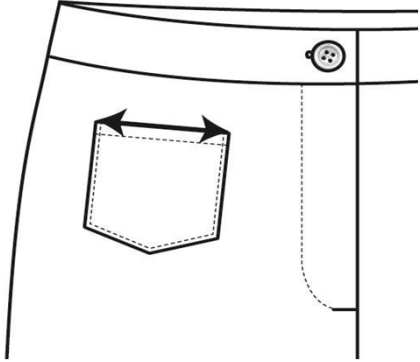
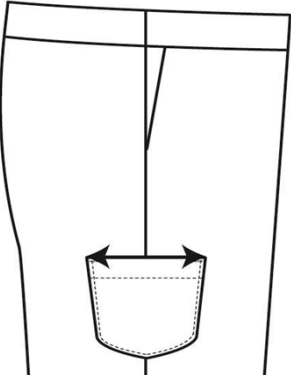
POM	Point of Measure	How To Measure Text	How To Measure Image
B430	Front Pocket Opening Below Waistband at Side Seam	Along side seam, measure from waist to the pocket opening.	
B431	Front Pocket Opening along Waist Seam	Along waist seam, measure from side seam to pocket opening.	
B432	Front Pocket Opening	Measure straight from top edge of pocket edge to edge	
B440	Side Pocket Width	Measure straight across top of pocket from edge to edge.	

TRAVELSMITH OUTFITTERS: How To Measure

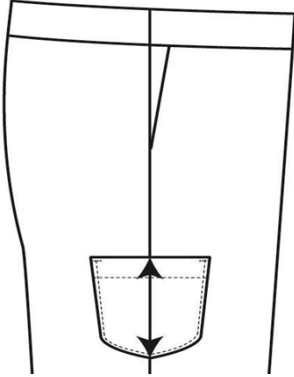
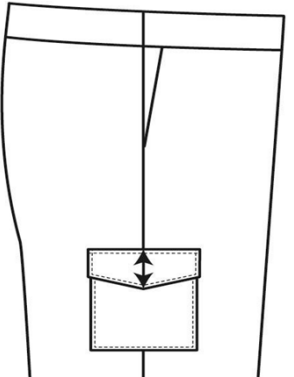
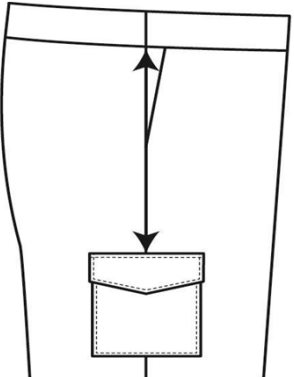
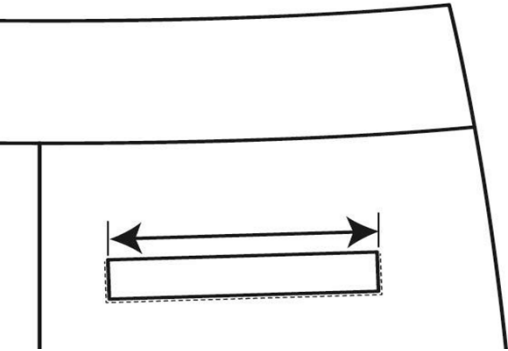
<u>POM</u>	<u>Point of Measure</u>	<u>How To Measure Text</u>	<u>How To Measure Image</u>
B441	Side Pocket Height	Measure at center of pocket straight from top edge to bottom edge.	
B442	Side Pocket Flap Height	Measure at center of pocket straight from top edge to bottom edge.	
B444	Side Pocket Position from Waist Seam	Along side seam, measure waist seam to top of pocket/flap.	
B450	Welt Pocket Length - Bottoms	Measure from edge to edge at top of welt.	

TRAVELSMITH OUTFITTERS: How To Measure

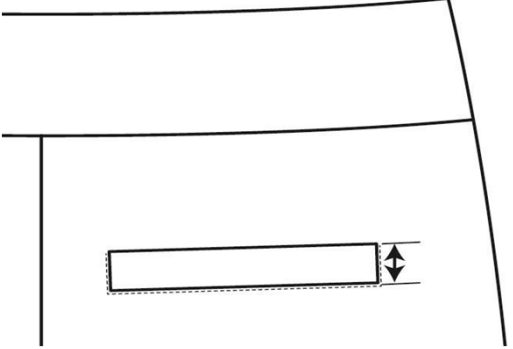
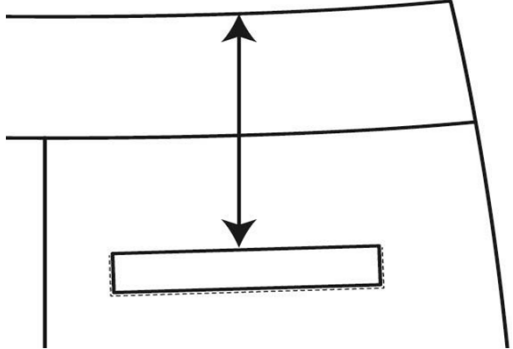
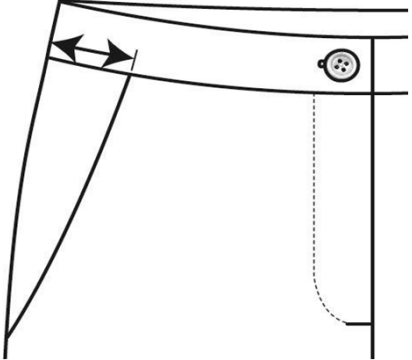
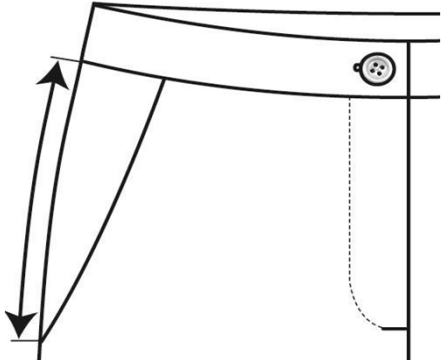
POM	Point of Measure	How To Measure Text	How To Measure Image
B451	Welt Pocket Height - Bottoms	Measure from top of welt to seam.	
B452	Welt Pocket Position from Top Edge	Measure from top edge of waist to top edge of welt.	
B470	Pocket Opening Horiz. from Side Seam at Waist	Along waist seam, measure from side seam to pocket opening.	
B471	Pocket Opening Vert. from Waist along SS	Along side seam, measure from waist to the pocket opening.	

TRAVELSMITH OUTFITTERS: How To Measure

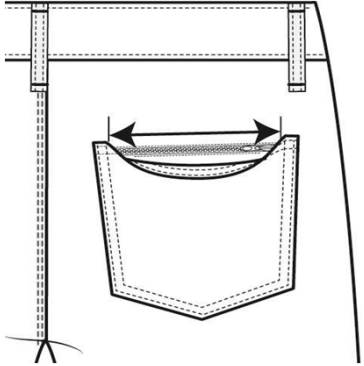
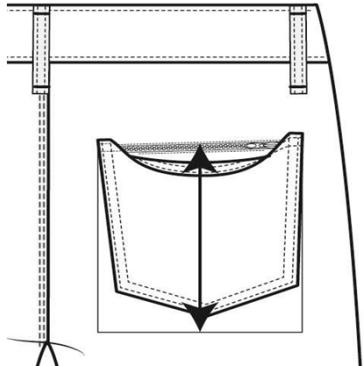
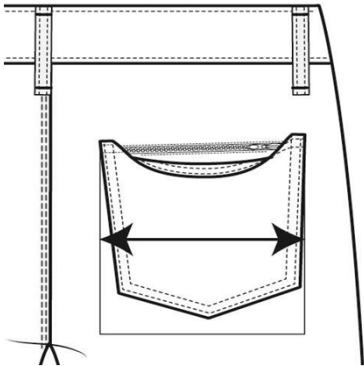
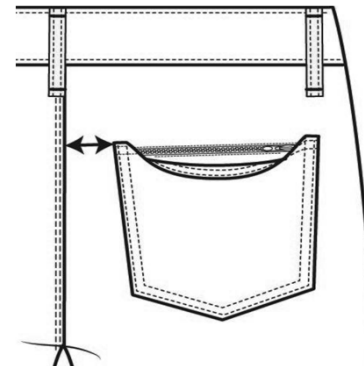
POM	Point of Measure	How To Measure Text	How To Measure Image
B480	Hidden Back Pocket Opening	Measure pocket opening from inside edge to inside edge.	
B481	Hidden Back Pocket Bag Height	Measure hidden pocket bag height from top opening to bottom finished edge.	
B482	Hidden Back Pocket Bag Width	Measure hidden pocket bag width from finished edge to finished edge.	
B483	Hidden Back Pocket Position from CB	Measure straight from top edge of pocket to center back seam.	

TRAVELSMITH OUTFITTERS: How To Measure

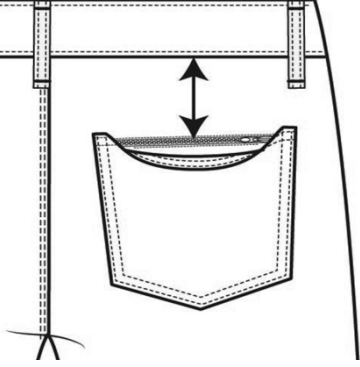
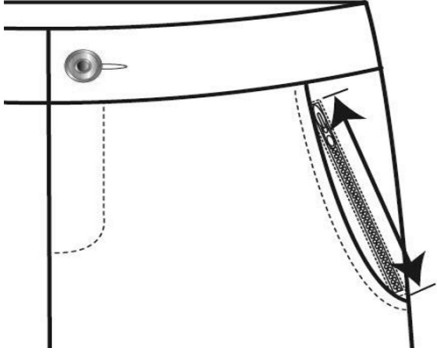
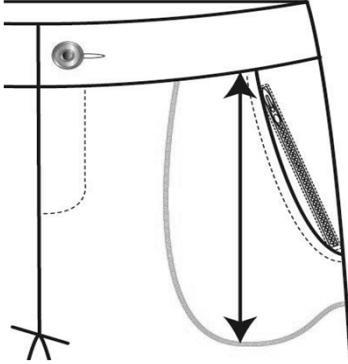
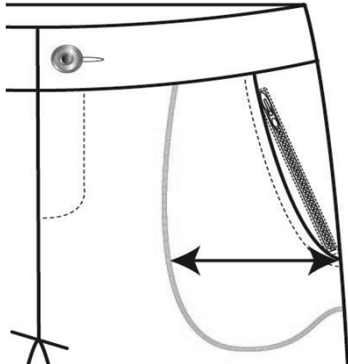
POM	Point of Measure	How To Measure Text	How To Measure Image
B484	Hidden Back Pocket Position from Waist Seam	Measure straight from top edge of pocket to side seam.	
B485	Hidden Front Pocket Opening	Measure pocket opening edge to edge.	
B486	Hidden Front Pocket Bag Height	Measure from waist seam to bottom finish of pocket bag.	
B487	Hidden Front Pocket Bag Width	Measure pocket bag width from bottom of pocket opening to finished edge.	

TRAVELSMITH OUTFITTERS: How To Measure

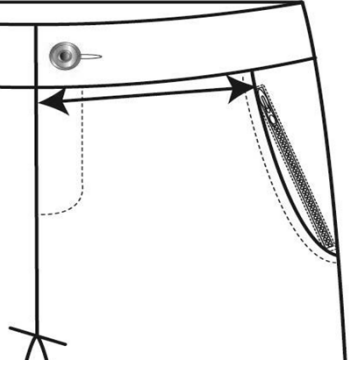
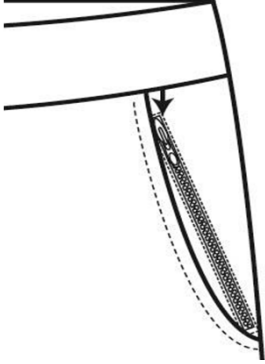
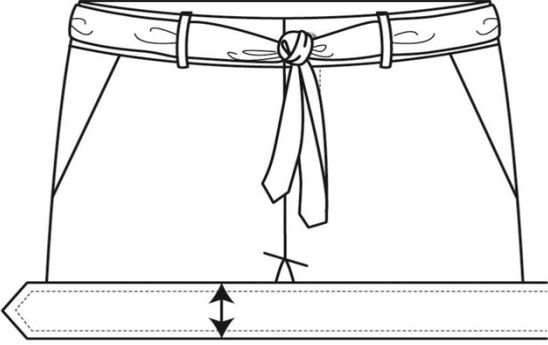
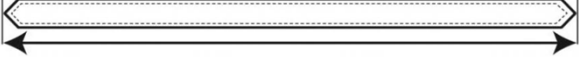
POM	Point of Measure	How To Measure Text	How To Measure Image
B488	Hidden Front Pocket Position from CF	Along waist seam, measure from center front to top of pocket opening.	 <p>The diagram shows a side view of a pair of pants with a hidden front pocket. A vertical dashed line indicates the center front. A horizontal double-headed arrow measures the distance from this center front line to the top edge of the pocket opening along the waistband.</p>
B489	Hidden Front Pocket Position from Waist Seam	From waist seam, measure from pocket opening.	 <p>The diagram shows a side view of a pair of pants with a hidden front pocket. A vertical dashed line indicates the waist seam. A vertical double-headed arrow measures the distance from the waist seam down to the top edge of the pocket opening.</p>
B490	Belt Width	Lay belt flat. Measure edge to edge.	 <p>The diagram shows a pair of pants with a belt tied around the waist. Below the pants, a separate belt is shown laid flat. A vertical double-headed arrow indicates the width of the belt, measured from one edge to the other.</p>
B491	Belt Length	Lay belt flat, at widest point measure end to end.	 <p>The diagram shows a belt laid flat. A horizontal double-headed arrow indicates the length of the belt, measured from the end to the end at its widest point.</p>

TRAVELSMITH OUTFITTERS: How To Measure

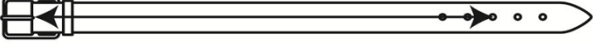
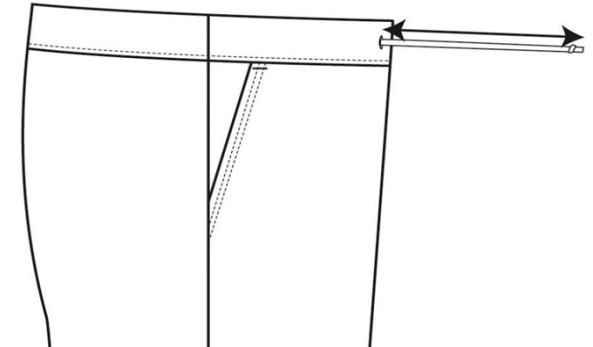
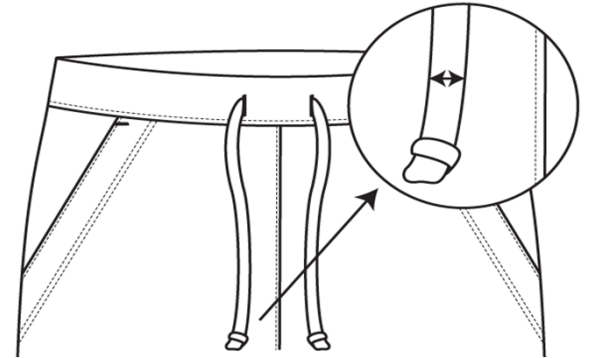
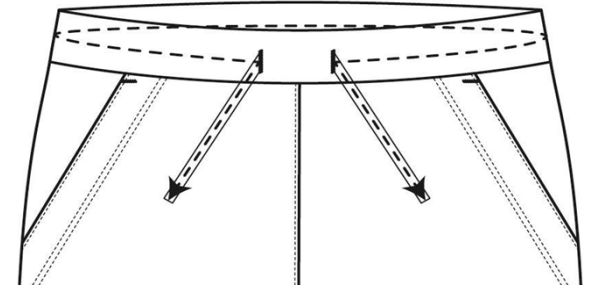
POM	Point of Measure	How To Measure Text	How To Measure Image
B492	Belt Length from Buckle to 3rd Grommet	Measure belt fold along center of belt to third grommet.	
B495	Tie Length	Measure tie length from waist to finished end.	
B496	Tie Width	Measure tie width edge to edge.	
B499	Drawcord Length	Measure on the half, from center back to end of drawcord, then double measurement.	

TRAVELSMITH OUTFITTERS: How To Measure

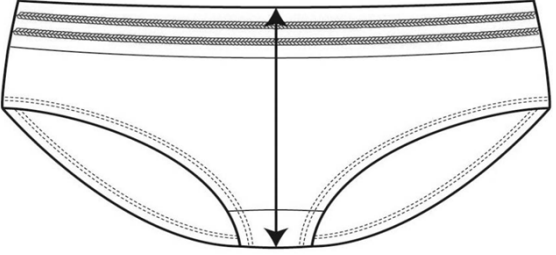
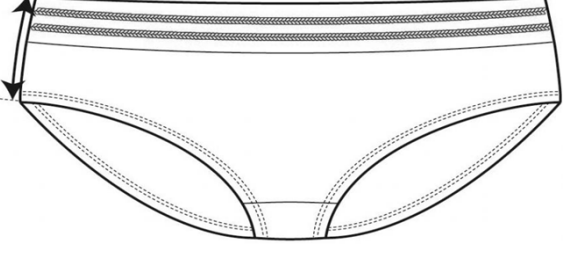
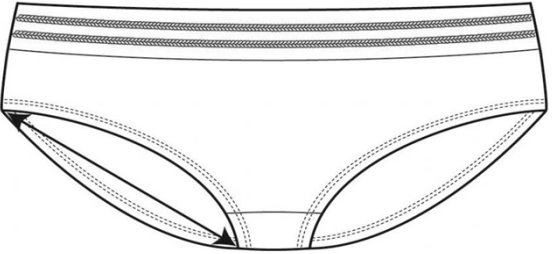
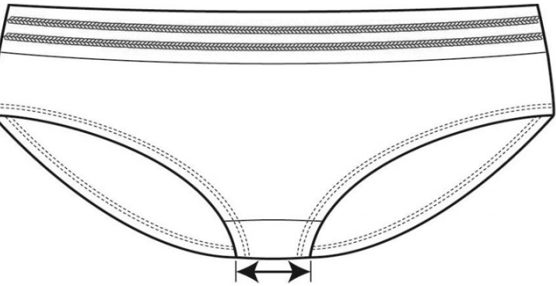
POM	Point of Measure	How To Measure Text	How To Measure Image
B650	Swim Liner - Height from Waist edge to Crotch	<ul style="list-style-type: none"> • Match the front waist to the back waist. • Measure straight down from the top of waist to the crotch panel fold. 	
B651	Swim Liner - Outseam at Fold	<ul style="list-style-type: none"> • Match front waist to back waist. • Along side, measure from top of waistband to top of leg opening. 	
B652	Swim Liner - Leg Opening	<ul style="list-style-type: none"> • Match the front waist to the back waist. • Measure straight across the leg opening from edge to edge. 	
B653	Swim Liner Crotch Width- at Fold	<ul style="list-style-type: none"> • Match front waist to back waist. • Measure crotch from leg opening to leg opening along fold. 	

TRAVELSMITH OUTFITTERS: How To Measure

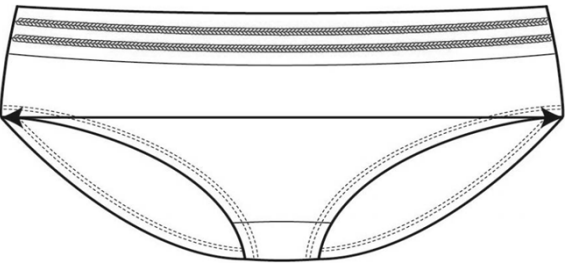
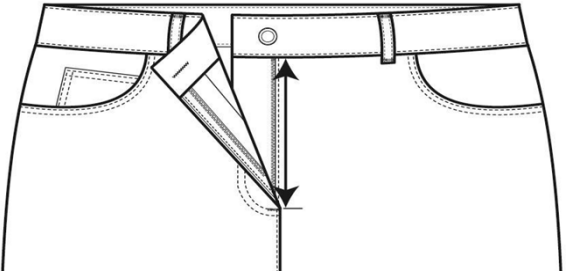
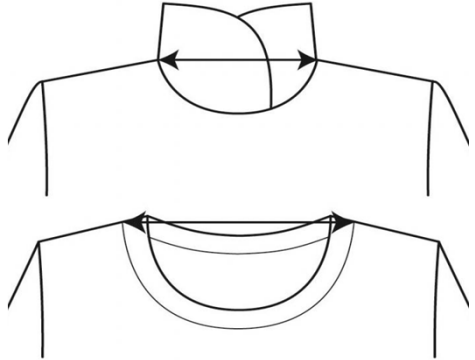
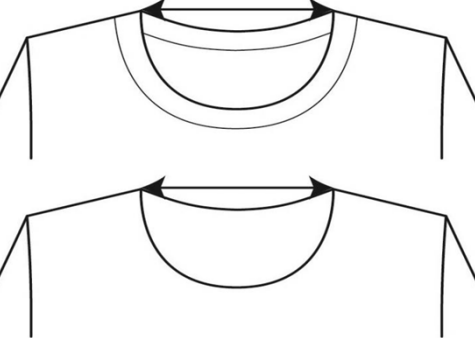
POM	Point of Measure	How To Measure Text	How To Measure Image
B654	Swim Hip Width at Top of Leg Openings	<ul style="list-style-type: none"> • Match front waist to back waist. • At top of leg opening, measure straight from fold to fold. 	
B900	Zipper Opening - Functional Fly	With the zipper open, measure from the top stop to the top of the zipper pull.	
T001	Neck Width - Seam to Seam	For styles with a neck band or collar, at front of garment, measure across neck from HPS to HPS (High Point of Shoulder).	
T002	Neck Width - Edge to Edge	For styles with a binding or clean finish neckline, at front of garment, measure across neck opening from inside edge to inside edge at HPS (High Point of Shoulder).	

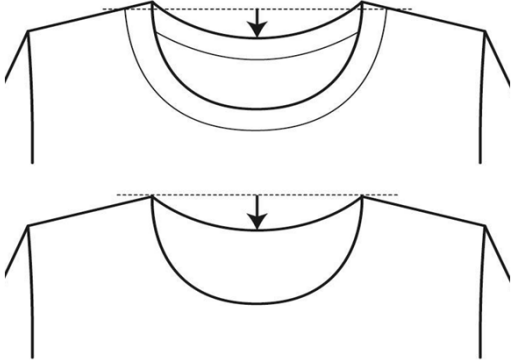
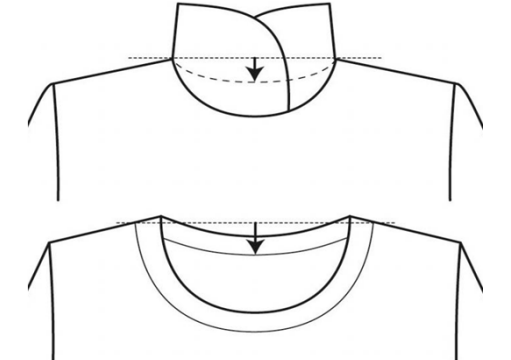
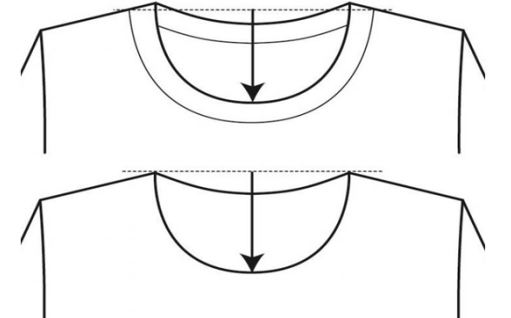
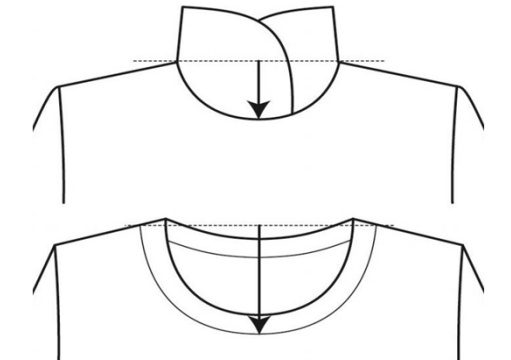

TRAVELSMITH OUTFITTERS: How To Measure

POM	Point of Measure	How To Measure Text	How To Measure Image
T005	Back Neck Drop - To Top Edge	For styles with a binding or clean finish neckline, at back of garment, measure from the center of the imaginary line across HPS (High Point of Shoulder) down to the edge of binding.	
T006	Back Neck Drop - To Seam	For styles with a neck band or collar, at back of garment, measure from the center of the imaginary line across HPS (High Point of Shoulder), down to the neck seam.	
T007	Front Neck Drop - To Top Edge	For styles with a binding or clean finish neckline, at front of garment, measure from the center of the imaginary line across HPS (High Point of Shoulder) down to the edge of binding.	
T008	Front Neck Drop - To Seam	For styles with a neck band or collar, at front of garment, measure from the center of the imaginary line across HPS (High Point of Shoulder), down to the neck seam.	

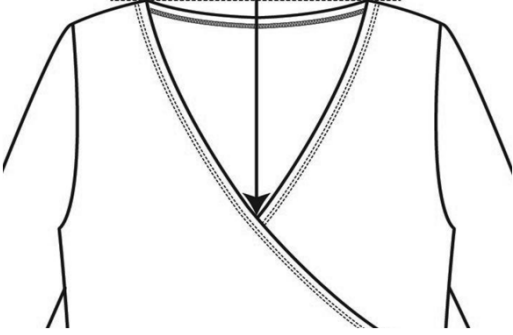
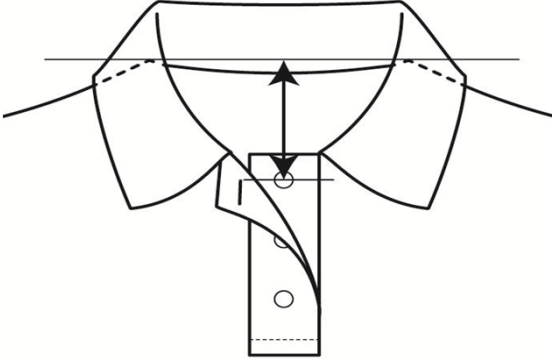
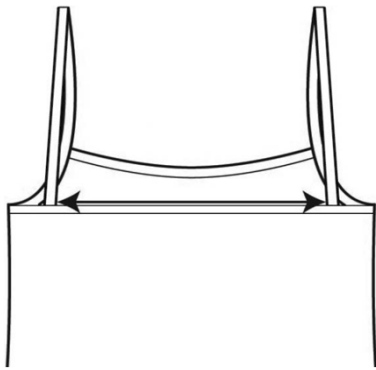
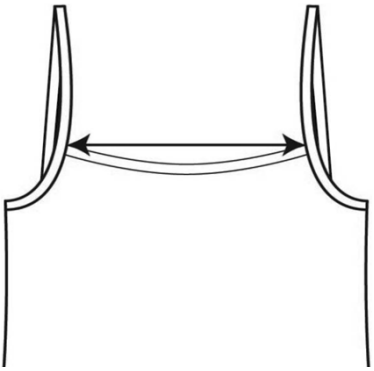
TRAVELSMITH OUTFITTERS: How To Measure

POM	Point of Measure	How To Measure Text	How To Measure Image
T009	Front Neck Drop - HPS (High Point of Shoulder) to crossover	<ul style="list-style-type: none"> • Lay garment flat, folded at the side seams. • At front of garment, measure from a line across HPS (High Point of Shoulder) to Center Front crossover. 	
T010	Front Neck Drop (polo) - To 1st Button	For styles with a convertible collar, at back of garment, measure from the center of the imaginary line across HPS (High Point of Shoulder) down to the first button.	
T020	Back Neck Width - between straps	At top of back, measure strap distance straight from inside edge to inside edge.	
T021	Front Neck Width - between straps	At top of front, measure strap distance straight from inside edge to inside edge.	

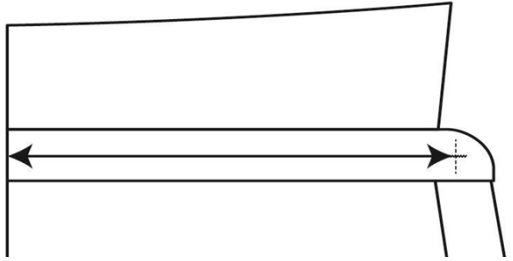
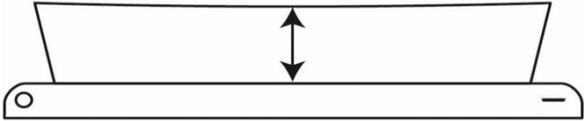
TRAVELSMITH OUTFITTERS: How To Measure

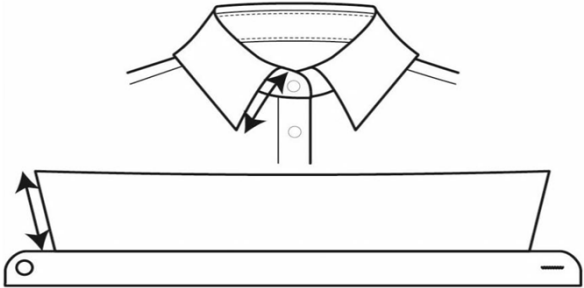
POM	Point of Measure	How To Measure Text	How To Measure Image
T030	Neck Circumference - Button Collar	Measure one half from center back to center button and double your measurement.	
T035	Collar Height at CB	Measure collar height at at CB from seam to edge.	
T036	Collar Band Height at CB	Measure from collar seam at CB straight up to neckband joining seam.	
T040	Collar Point	Measure from collar join seam to collar point.	

TRAVELSMITH OUTFITTERS: How To Measure

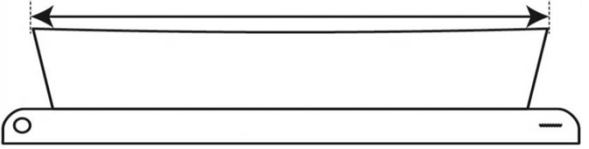
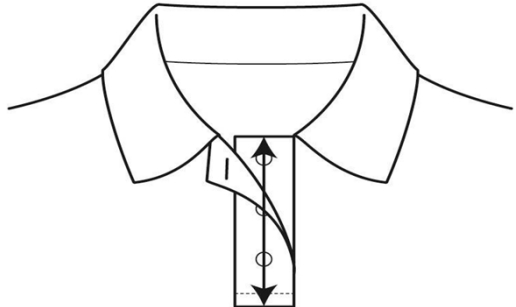
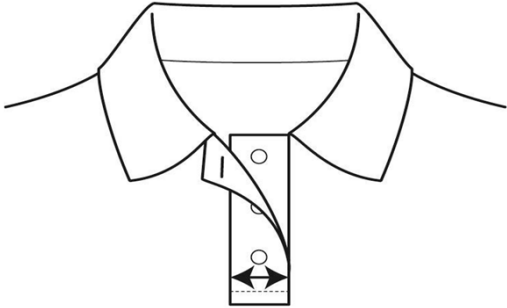
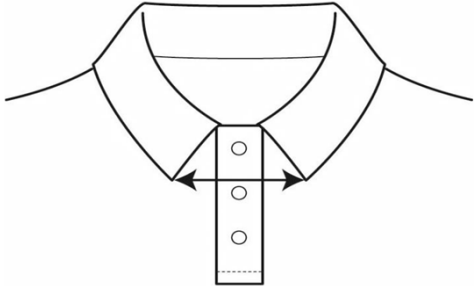
POM	Point of Measure	How To Measure Text	How To Measure Image
T041	Collar Length at Outer Edge	Measure point to point on the outer edge of the collar.	 <p>A technical line drawing of a collar. A horizontal double-headed arrow spans the width of the collar at its outer edge, indicating the measurement point.</p>
T045	Front Placket Length (Polo/Tunic)	With the placket open, measure from the top of placket to the bottom of placket.	 <p>A line drawing of a polo shirt collar. A vertical double-headed arrow is positioned on the front placket, extending from the top edge to the bottom edge to show the measurement.</p>
T046	Front Placket Width	Measure seam to opening edge.	 <p>A line drawing of a polo shirt collar. A horizontal double-headed arrow is positioned on the front placket, measuring from the side seam to the opening edge.</p>
T050	Tie Space at Neck (also Collar Point Spread)	With garment flat, measure between collar points.	 <p>A line drawing of a polo shirt collar. A horizontal double-headed arrow is positioned between the two collar points at the neck, indicating the measurement.</p>

TRAVELSMITH OUTFITTERS: How To Measure

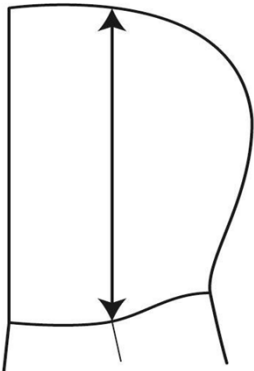
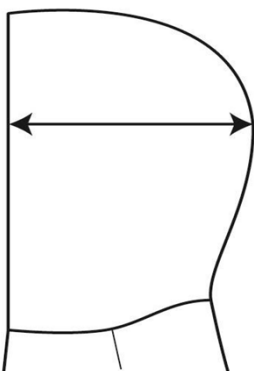
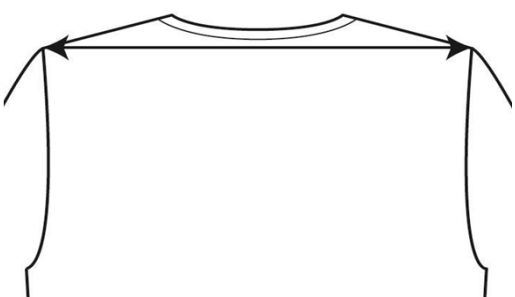
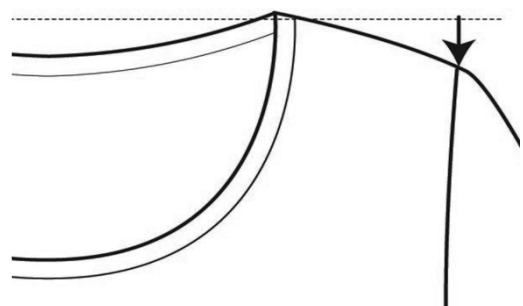
POM	Point of Measure	How To Measure Text	How To Measure Image
T090	Hood Height: From Shoulder Point to Top Edge	<ul style="list-style-type: none"> • Fold the hood in half matching the edges. • Measure from HPS (High Point of Shoulder) to top of hood. 	
T091	Hood Width: @ Widest	<ul style="list-style-type: none"> • Fold the hood in half matching the front edges. • At the widest point, measure straight across from edge to edge. 	
T100	Across Shoulder - at Back	On the back of the garment, measure straight across from shoulder point to shoulder point.	
T105	Shoulder Slope	On the front of the garment, measure from the imaginary line across HPS (High Point of Shoulder) down to the shoulder point.	

TRAVELSMITH OUTFITTERS: How To Measure

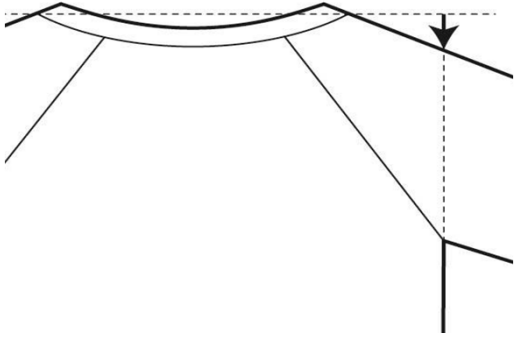
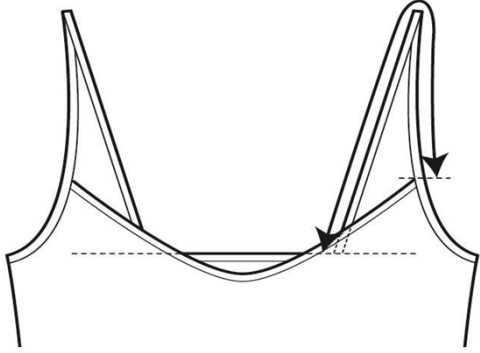
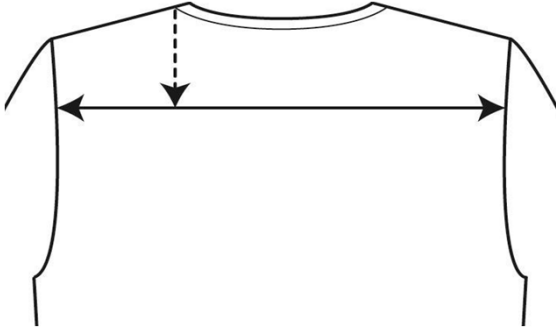
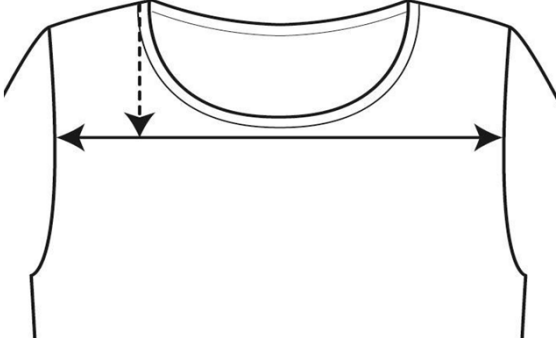
POM	Point of Measure	How To Measure Text	How To Measure Image
	Shoulder Slope (Dropped shoulder)	On drop shoulder styles, shoulder point is found by drawing a line straight up the side seam to the top of the garment.	
T108	Strap Length - (Extended or Nonadjusting)	With the strap fully extended, measure from the front strap junction to the back strap junction.	
T110	Across Back - (4 1/2") Below HPS (Missy/Petite)	<ul style="list-style-type: none"> • On the back of the garment, measure down specified distance from the HPS (High Point of Shoulder). • Then measure straight across from armhole seam to seam. 	
T115	Across Front - (4 1/2") Below HPS (Missy/Petite)	<ul style="list-style-type: none"> • From the front of the garment, measure down specified distance from the HPS (High Point of Shoulder). • Then measure straight across from armhole seam to seam. 	

TRAVELSMITH OUTFITTERS: How To Measure

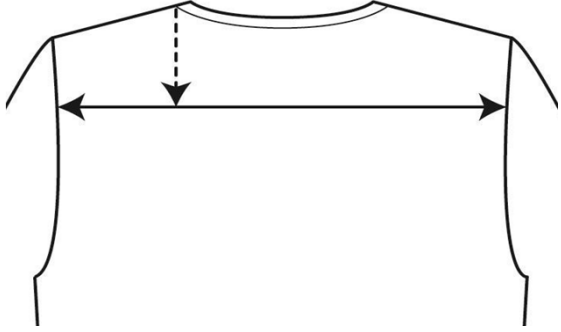
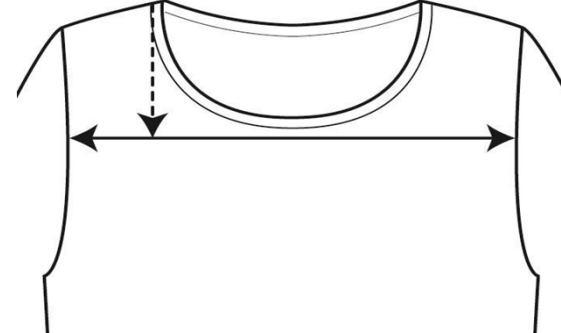
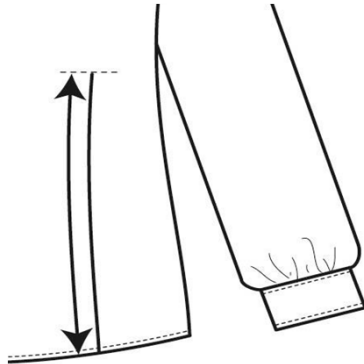
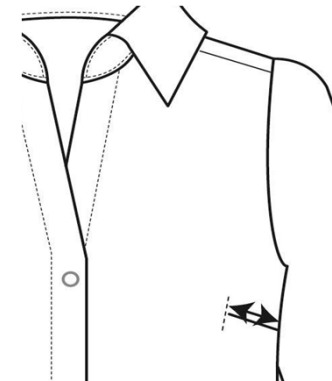
POM	Point of Measure	How To Measure Text	How To Measure Image
T116	Across Back - (5") Below HPS (Plus)	<ul style="list-style-type: none"> • On the back of the garment, measure down specified distance from the HPS (High Point of Shoulder). • Then measure straight across from armhole seam to seam. 	
T117	Across Front - (5") Below HPS (Plus)	<ul style="list-style-type: none"> • From the front of the garment, measure down specified distance from the HPS (High Point of Shoulder). • Then measure straight across from armhole seam to seam. 	
T118	Dart Length:@ Back Waist	Measure from edge of finished hem to end of dart.	
T119	Dart Length:@ Bust	Measure from side seam to end of dart.	

TRAVELSMITH OUTFITTERS: How To Measure

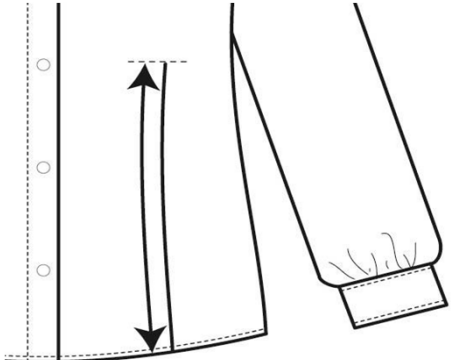
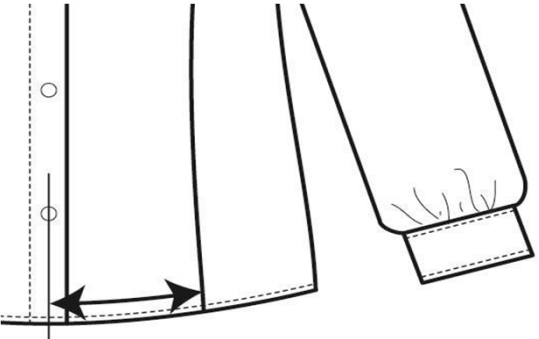
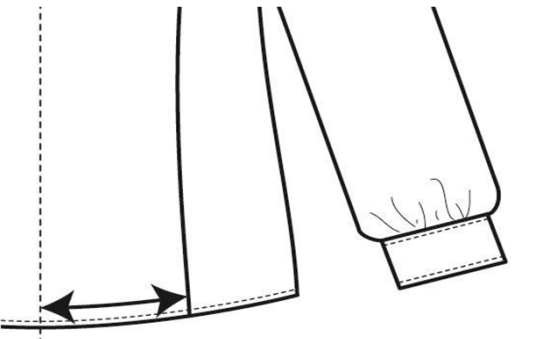
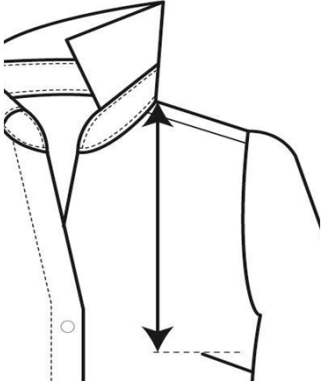
POM	Point of Measure	How To Measure Text	How To Measure Image
T120	Dart Length:@ Front Waist	Measure from edge of finished hem to end of dart.	
T121	Dart Placement From CF	Measure from Center Front to dart.	
T122	Dart Placement From CB	<ul style="list-style-type: none"> • Locate center back. • Measure from Center Back to dart. 	
T123	Dart Placement From HPS	<ul style="list-style-type: none"> • Draw an imaginary horizontal line from side seam to dart point. • Measure from HPS (High Point of Shoulder) to imaginary horizontal line. • For garments with a forward rolling shoulder, the HPS (High Point of Shoulder) will be located at the fold when the garment is laid flat, not at the shoulder seam. 	

TRAVELSMITH OUTFITTERS: How To Measure

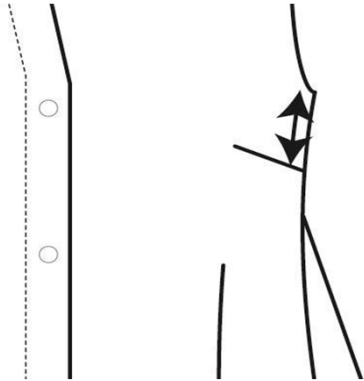
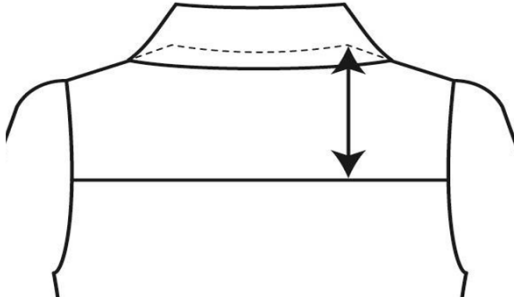
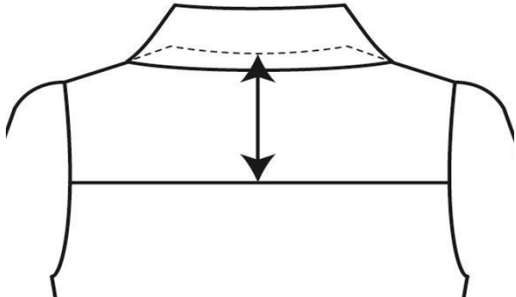
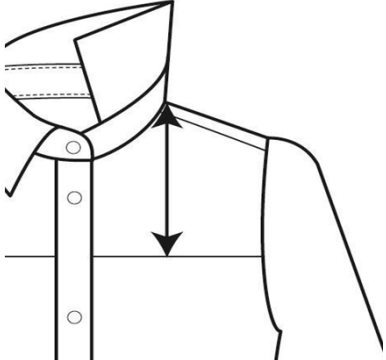
POM	Point of Measure	How To Measure Text	How To Measure Image
T124	Dart Placement From underarm	Measure from armhole seam to dart along side seam.	
T125	Back Yoke Height from HPS - Tops	Measure from the HPS (High Point of Shoulder) to yoke seam.	
T126	Back Yoke Height from CB - Tops	<ul style="list-style-type: none"> • Locate center back along neck seam. • Measure from center back neck to yoke seam. 	
T127	Front Yoke Height from HPS - Tops	<ul style="list-style-type: none"> • Measure from the HPS (High Point of Shoulder) to yoke seam. • For garments with a forward rolling shoulder, the HPS (High Point of Shoulder) will be located at the fold when the garment is laid flat, not at the shoulder seam. 	

TRAVELSMITH OUTFITTERS: How To Measure

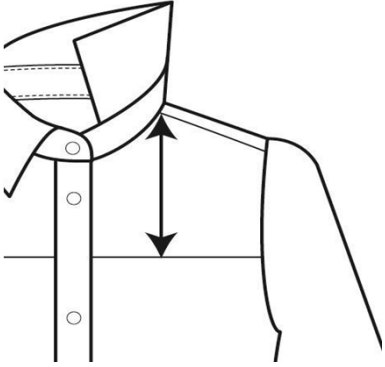
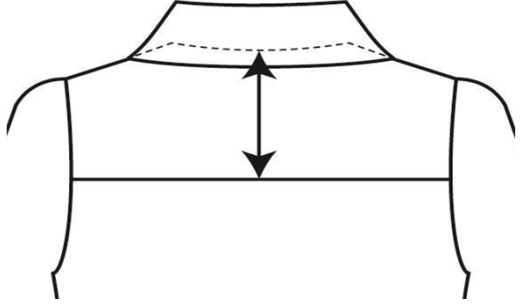
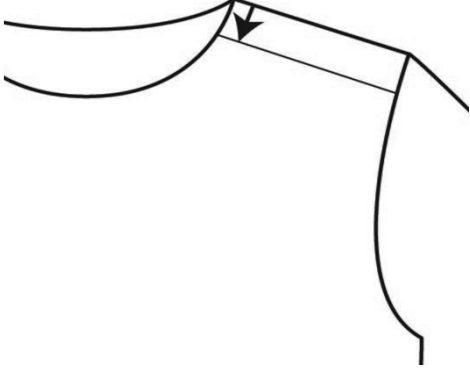
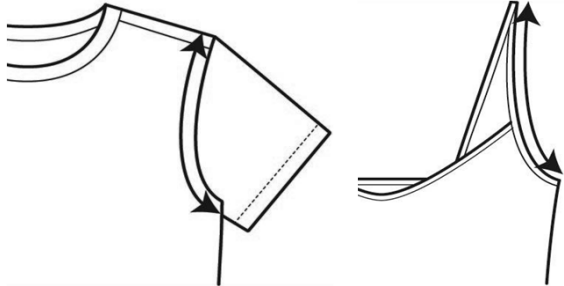
POM	Point of Measure	How To Measure Text	How To Measure Image
T128	Front Yoke Height from Shoulder Seam - Tops	Measure from shoulder seam to yoke seam.	 <p>A line drawing of a shirt collar and shoulder area. A vertical double-headed arrow indicates the measurement from the shoulder seam to the top of the yoke seam.</p>
T129	Back Yoke Height at CB	<ul style="list-style-type: none"> • Locate center back neck along neck seam. • Measure from the neck seam to the yoke seam. 	 <p>A line drawing of the back of a shirt. A vertical double-headed arrow indicates the measurement from the center back neck seam to the top of the yoke seam.</p>
T130	Shoulder Seam Forward from HPS	Measure from natural fold at HPS (High Point of Shoulder) to shoulder seam.	 <p>A line drawing of a shirt sleeve. An arrow points to the natural fold at the high point of the shoulder, and another arrow points to the shoulder seam, indicating the measurement between them.</p>
T135	Armhole - Along Seam	Lay garment flat. On front of body, following the armhole seam, measure from the top of the armhole to the underarm edge. Double measurement, for garments with a forward rolling shoulder, the top of armhole will be located at the fold when the garment is laid flat, not at shoulder seam.	 <p>Two line drawings illustrating armhole measurement. The left drawing shows a garment laid flat with an arrow following the armhole seam from the top to the underarm edge. The right drawing shows a garment with a forward rolling shoulder, with an arrow following the seam from the top of the armhole to the underarm edge.</p>

TRAVELSMITH OUTFITTERS: How To Measure

POM	Point of Measure	How To Measure Text	How To Measure Image
T136	Armhole Straight	Lay garment flat. On front of body, measure straight from the top of the armhole to the underarm edge. For garments with a forward rolling shoulder, the top of armhole will be located at the fold when the garment is laid flat, not at shoulder seam.	
T140	Back Raglan Position below HPS at Neck	On back of garment measure at HPS (High Point of Shoulder) from fold to raglan seam.	
T141	Back Raglan Armhole - Along Seam	<ul style="list-style-type: none"> • Lay garment flat. • On back of garment, follow contour of armhole seam and measure from neck seam to underarm seam. 	
T142	Back Raglan Width - seam to seam	On back of garment, measure straight across from top of one raglan seam to top of other raglan seam.	

TRAVELSMITH OUTFITTERS: How To Measure

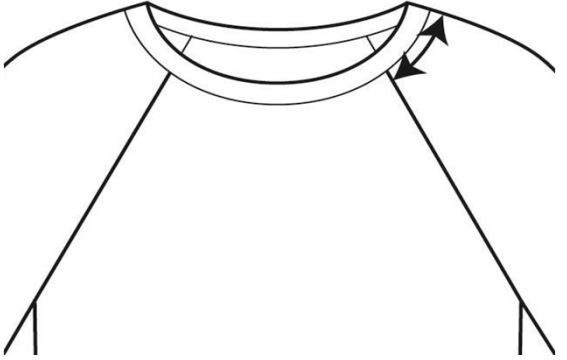
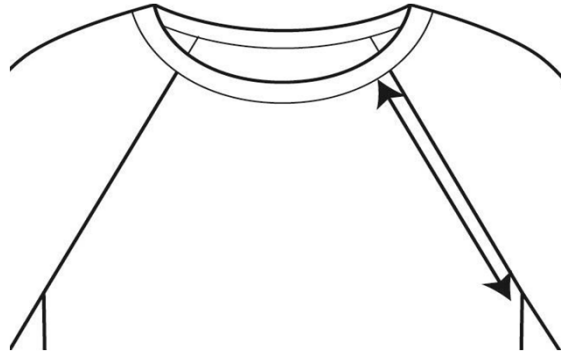
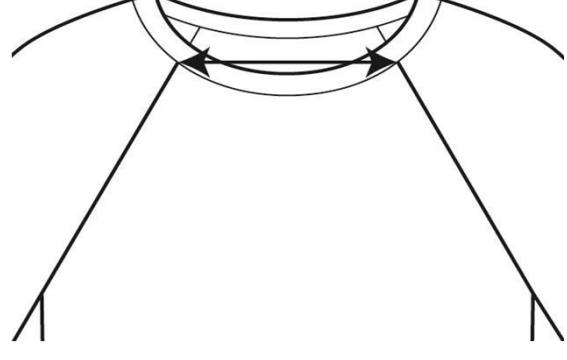
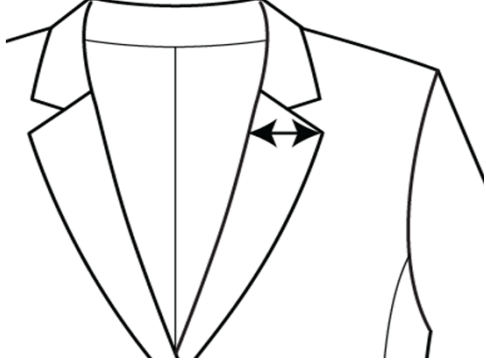
POM	Point of Measure	How To Measure Text	How To Measure Image
T145	Front Raglan Position below HPS at Neck	On Front of garment measure at HPS (High Point of Shoulder) from fold to raglan seam.	
T146	Front Raglan Armhole - Along Seam	<ul style="list-style-type: none"> • Lay garment flat. • On front of garment, follow contour of armhole seam and measure from neck seam to underarm seam. 	
T147	Front Raglan Width - seam to seam	On front of garment, measure straight across from top of one raglan seam to top of other raglan seam.	
T159	Lapel Width	Measure from natural fold to lapel edge.	

TRAVELSMITH OUTFITTERS: How To Measure

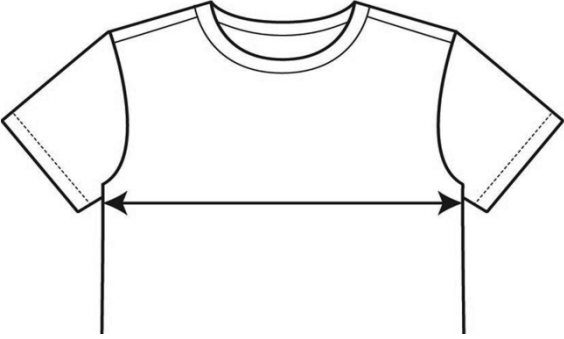
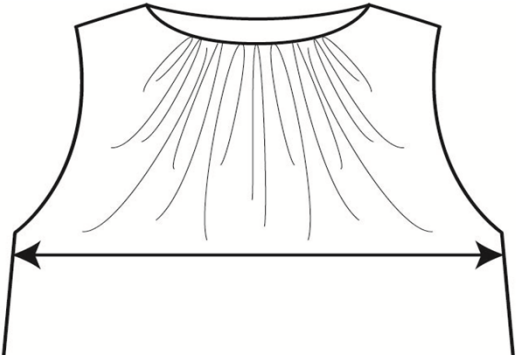
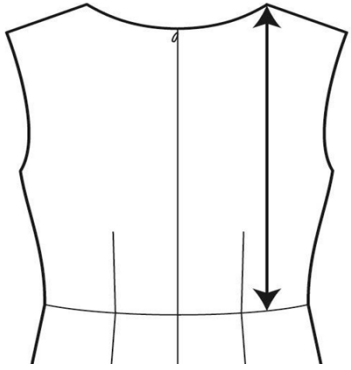
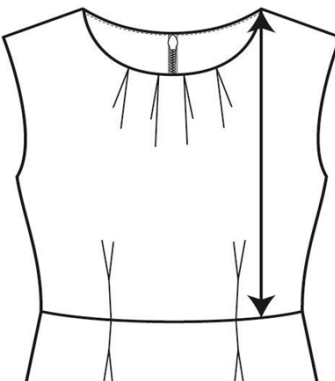
POM	Point of Measure	How To Measure Text	How To Measure Image
T160	Chest Width - 1" Below Armhole	<ul style="list-style-type: none"> • Smooth garment flat. • On the front of the garment, measure straight across the chest 1" below armhole, edge to edge. 	
T161	Chest Width - 1" Below Armhole, Open Gathers	<ul style="list-style-type: none"> • Open any gathers. • On front of the garment, measure straight across the chest 1" below armhole, edge to edge. 	
T165	Back Bodice Seam Placement - from HPS	On back of garment, measure from HPS (High Point of Shoulder) to waist seam.	
T166	Front Bodice Seam Placement - from HPS	On front of garment, measure from HPS (High Point of Shoulder) to waist seam.	

TRAVELSMITH OUTFITTERS: How To Measure

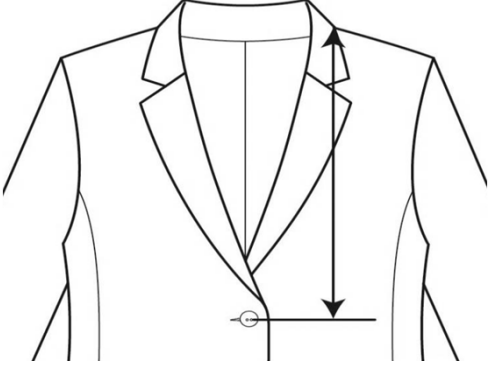
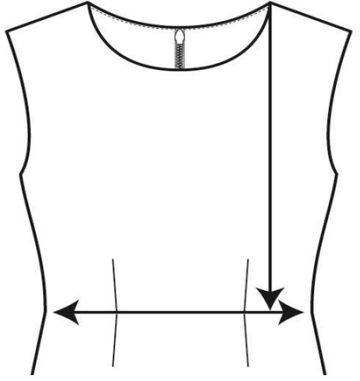
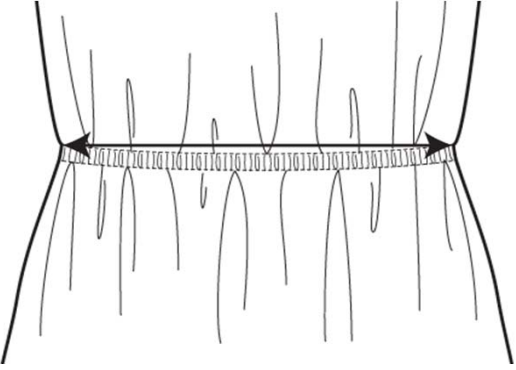
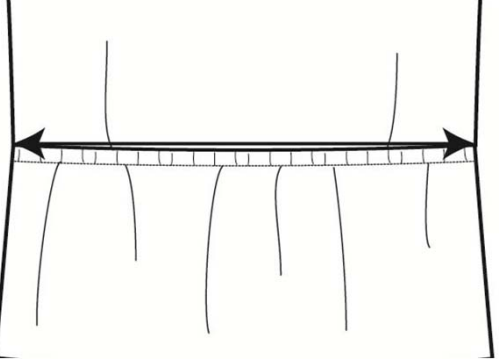
<u>POM</u>	<u>Point of Measure</u>	<u>How To Measure Text</u>	<u>How To Measure Image</u>
T169	Button Placement from HPS (blazer)	Create imaginary horizontal line across center of 1st button. Measure from HPS (High Point of Shoulder) straight down to imaginary horizontal line.	
T170	Waist Measurement Position - below HPS	On front of garment, measure to specified distance from HPS (High Point of Shoulder). Measure waist width at this position from edge to edge. Double measurement.	
T171	Waist - Relaxed	Match the front waist to the back waist. Measure from st top of waist from edge to edge. Double measurement.	
T172	Waist - Extended	Match the front waist to the back waist. Measure at top of waist from edge to edge with elastic fully stretched. Do not overstretch. Double measurement.	

TRAVELSMITH OUTFITTERS: How To Measure

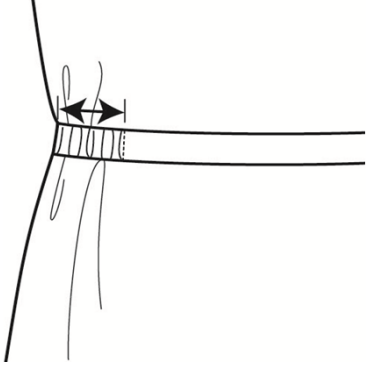
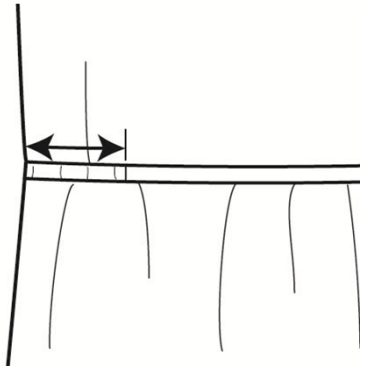
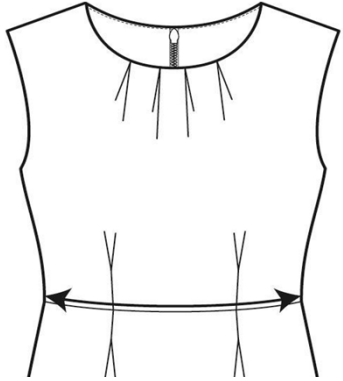
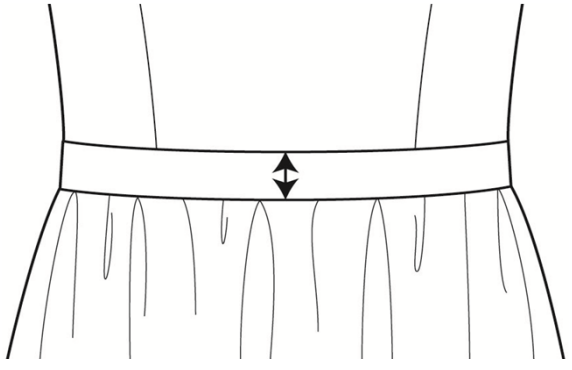
POM	Point of Measure	How To Measure Text	How To Measure Image
T173	Side Waist Elastic - Relaxed	Measure at top of waist from seam to seam or stitch to stitch	
T174	Side Waist Elastic - Extended	Measure at top of waist from seam to seam or stitch to stitch with elastic fully stretched. Do not overstretch. Double measurement.	
T179	Waist Width at Waist Seam	On front of garment, measure from edge to edge along the waist seam.	
T183	Waistband Height	Measure from top edge to bottom edge of waistband seam.	

TRAVELSMITH OUTFITTERS: How To Measure

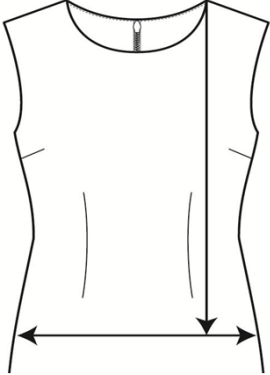
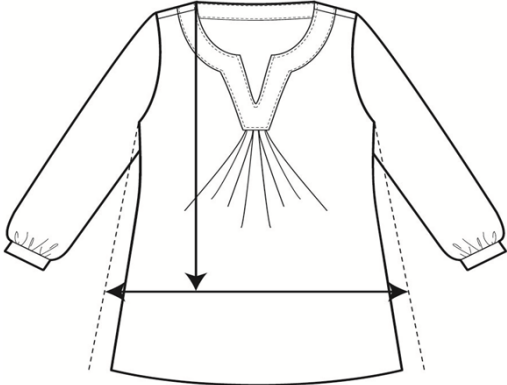
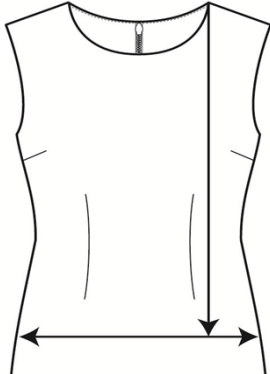
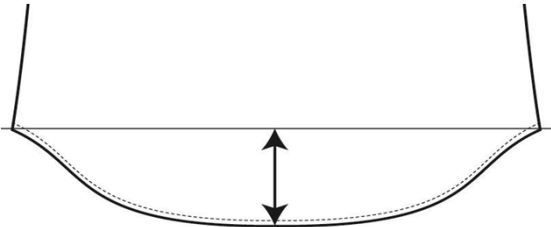
POM	Point of Measure	How To Measure Text	How To Measure Image
T184	Hip Measurement Position - below HPS	On front of garment, measure to this distance from HPS (High Point of Shoulder). Measure hip width at this position from edge to edge.	
T188	Low Hip Width: Open Gathers - Straight - Below HPS	<ul style="list-style-type: none"> • Lay garment flat. • Spread gathers, without stretching garment. • Measure down specified distance from HPS (High Point of Shoulder), then measure straight across from edge to edge. 	
T191	Low Hip Width: Straight - Below HPS	<ul style="list-style-type: none"> • Lay garment flat. • Measure down specified distance from the HPS (High Point of Shoulder), then measure straight across from edge to edge. 	
T198	Shirttail Height	<ul style="list-style-type: none"> •As specified front or back. • Lay garment flat, mark a line straight across from edge to edge at bottom of side fold/seam. • From the center of this line, measure straight down to the bottom of garment edge. 	

TRAVELSMITH OUTFITTERS: How To Measure

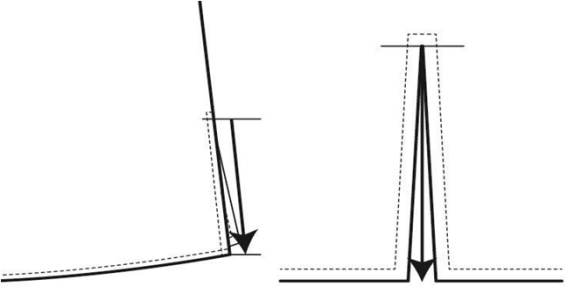
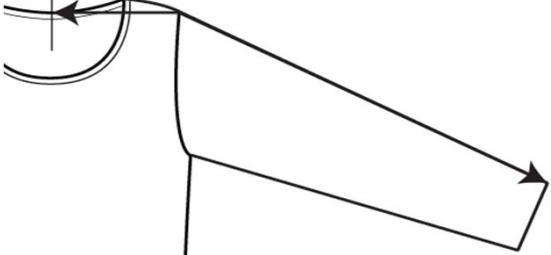
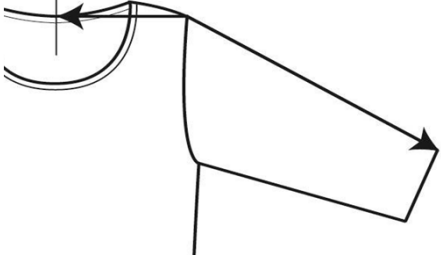
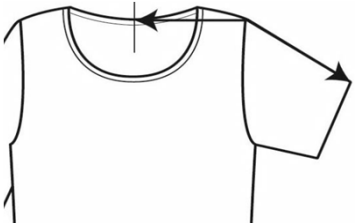
POM	Point of Measure	How To Measure Text	How To Measure Image
T199	Vent Height from hem	Measure total vent opening from top edge of opening to bottom edge.	
T200	Sleeve Length - at CB (Set-in Sleeve, Long)	<ul style="list-style-type: none"> • Mark 1/2 of Across Shoulder measurement at center back neck. • From center back neck point measure straight to shoulder seam then straight to bottom of sleeve opening. 	
T201	Sleeve Length - at CB (Set-in Sleeve, 3/4)	<ul style="list-style-type: none"> • Mark 1/2 of Across Shoulder measurement at center back neck. • From center back neck point measure straight to shoulder seam then straight to bottom of sleeve opening. 	
T202	Sleeve Length - at CB (Set-in Sleeve, Short)	<ul style="list-style-type: none"> • Mark 1/2 of Across Shoulder measurement at center back neck. • From center back neck point measure straight to shoulder seam then straight to bottom of sleeve opening. 	

TRAVELSMITH OUTFITTERS: How To Measure

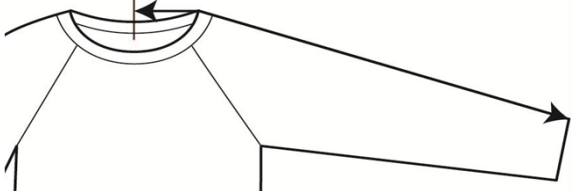
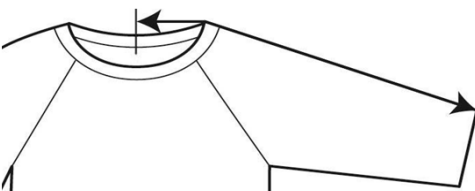
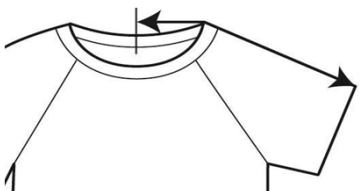
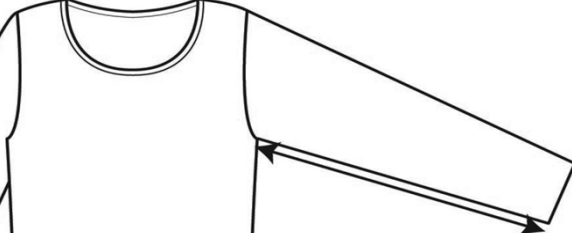
POM	Point of Measure	How To Measure Text	How To Measure Image
T205	Sleeve Length - at CB (Raglan Sleeve, Long)	<ul style="list-style-type: none"> • Mark 1/2 of Across Shoulder measurement at center back neck. • From center back neck point measure straight to HPS (High Point of Shoulder) then straight to bottom of sleeve opening. 	
T206	Sleeve Length - at CB (Raglan Sleeve, 3/4)	<ul style="list-style-type: none"> • Mark 1/2 of Across Shoulder measurement at center back neck. • From center back neck point measure straight to HPS (High Point of Shoulder) then straight to bottom of sleeve opening. 	
T207	Sleeve Length - at CB (Raglan Sleeve, Short)	<ul style="list-style-type: none"> • Mark 1/2 of Across Shoulder measurement at center back neck. • From center back neck point measure straight to HPS (High Point of Shoulder) then straight to bottom of sleeve opening. 	
T210	Underarm Sleeve Length	Measure from bottom of armhole to edge of sleeve opening.	

TRAVELSMITH OUTFITTERS: How To Measure

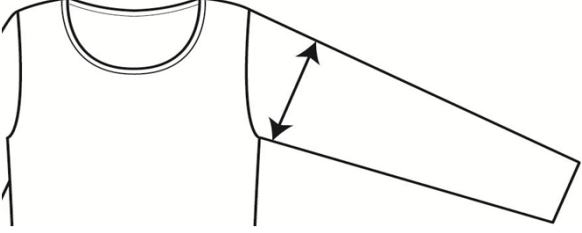
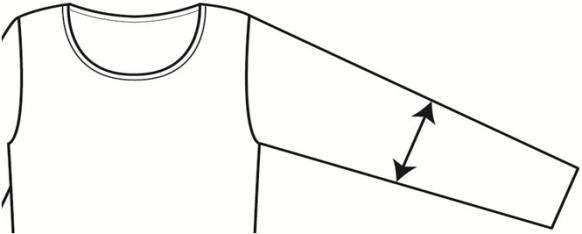
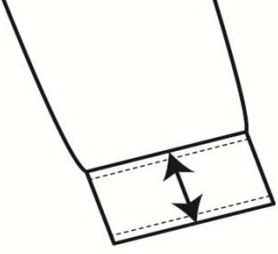
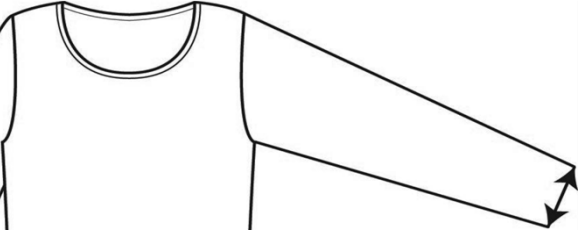
POM	Point of Measure	How To Measure Text	How To Measure Image
T225	Muscle - 1" Below Armhole	<ul style="list-style-type: none"> • Lay garment and sleeve flat. • Measure from sleeve inseam to outer sleeve edge 1" below underarm perpendicular to out seam. 	
T230	Elbow - at 1/2 of Slv Inseam	<ul style="list-style-type: none"> • Lay garment and sleeve flat. • Measure from sleeve inseam to outer sleeve edge at mid point of the underarm perpendicular to out seam. 	
T250	Sleeve Cuff Height	Measure from cuff seam to sleeve opening.	
T251	Sleeve Cuff/Opening (long sleeve)	Measure the opening width - inside edge to inside edge.	

TRAVELSMITH OUTFITTERS: How To Measure

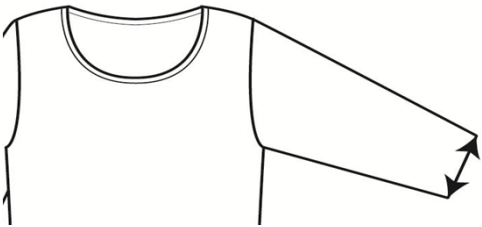
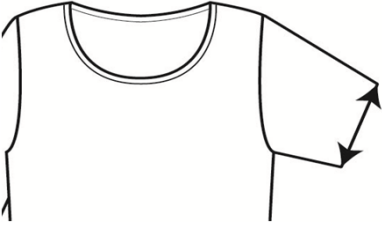
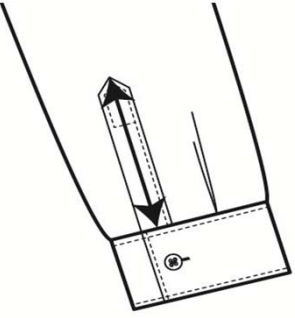
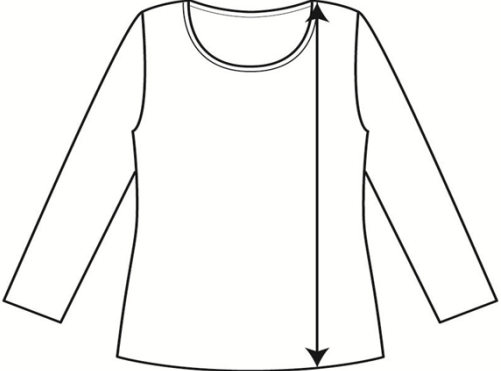
POM	Point of Measure	How To Measure Text	How To Measure Image
T252	Sleeve Cuff/Opening (3/4 sleeve)	Measure the opening width - inside edge to inside edge.	
T253	Sleeve Cuff Opening (short)	Measure the opening width - inside edge to inside edge.	
T259	Placket Length - sleeve	Measure total placket length from the top edge of cuff seam.	
T260	Body Length - from HPS (Tops)	<ul style="list-style-type: none"> • On front of garment, measure from HPS (High Point of Shoulder) straight down to bottom edge of the garment. • For garments with a forward rolling shoulder, the HPS (High Point of Shoulder) will be located at the fold when the garment is laid flat, not at the shoulder seam. 	

TRAVELSMITH OUTFITTERS: How To Measure

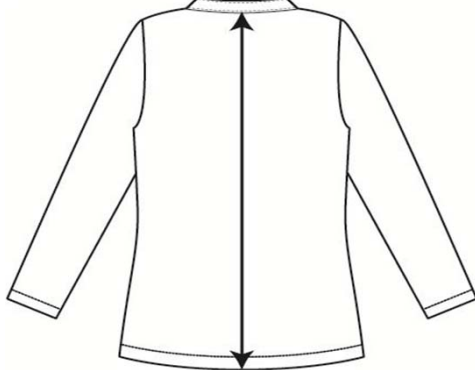
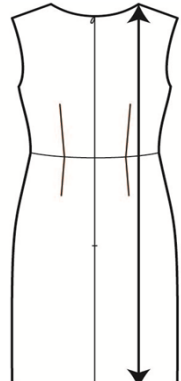
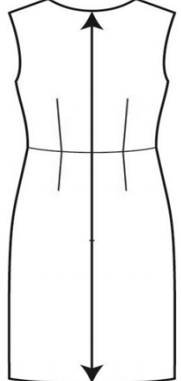
POM	Point of Measure	How To Measure Text	How To Measure Image
T261	Body Length From Center Back Neck Edge (Tops)	On back of garment, measure from center back neck edge straight down to bottom edge of the garment.	
T267	Body Length From Center Back Neck Seam (Tops)	On back of garment, measure from center back neck seam straight down to bottom edge of garment.	
T262	Body Length Back From HPS (Dresses)	On back of garment, measure from HPS (High Point of Shoulder) straight down to bottom edge of garment.	
T263	Body Length - From Center Back Neck Edge (Dress)	On back of garment, measure from center back neck edge straight down to bottom edge of garment.	

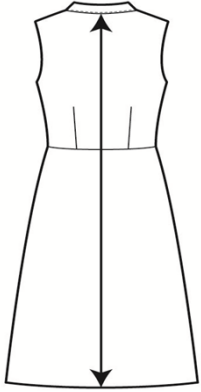
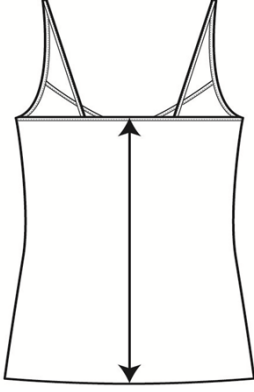
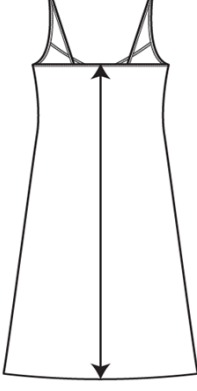
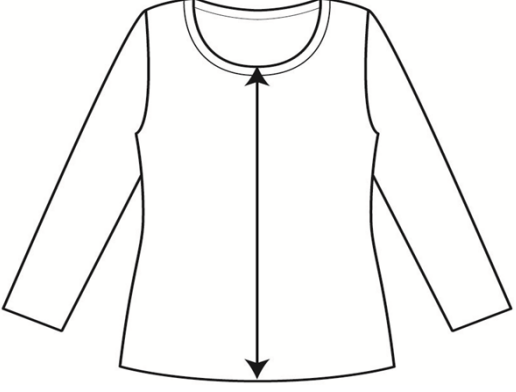

TRAVELSMITH OUTFITTERS: How To Measure

<u>POM</u>	<u>Point of Measure</u>	<u>How To Measure Text</u>	<u>How To Measure Image</u>
T264	Body Length From Center Back Neck Seam (Dresses)	On back of garment, measure from center back neck seam straight down to bottom edge of garment.	
T265	Body Length From Center Back Top Edge (tops)	On back of garment, measure from center back top edge to bottom edge of garment.	
T266	Body Length From Center Back Top Edge (Dresses)	On back of garment, measure from center back top edge to bottom edge of garment.	
T270	Body Length From Center Front Top Edge (Tops)	On front of garment, measure from center front top edge straight down to bottom edge of garment.	

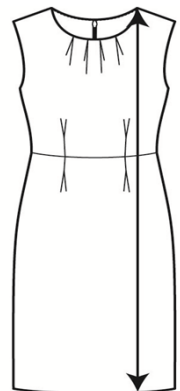
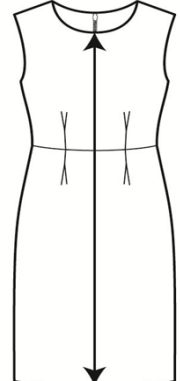
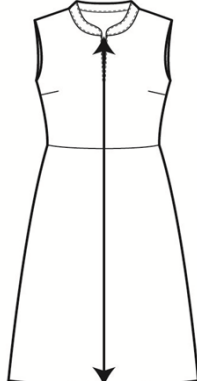
TRAVELSMITH OUTFITTERS: How To Measure

<u>POM</u>	<u>Point of Measure</u>	<u>How To Measure Text</u>	<u>How To Measure Image</u>
T272	Body Length From Center Front Neck Seam	On front of garment, measure from center front neck seam straight down to bottom edge of the garment.	
T271	Body Length Front From HPS (dresses)	<ul style="list-style-type: none"> • On front of garment, measure from HPS (High Point of Shoulder) straight down to the bottom edge of the garment. • For garments with a forward rolling shoulder, the HPS (High Point of Shoulder) will be located at the fold when the garment is laid flat, not at the shoulder seam. 	
T273	Body Length From Center Front Neck Edge (dresses)	On front of garment, measure from center front neck edge straight down to bottom edge of the garment.	
T274	Body Length From Center Front Neck Seam (dresses)	On front of garment, measure from center front neck seam straight down to bottom edge of garment.	

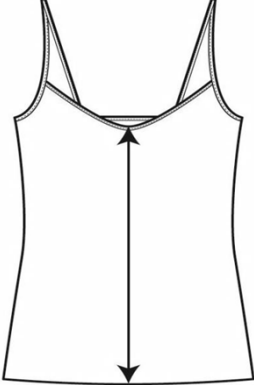
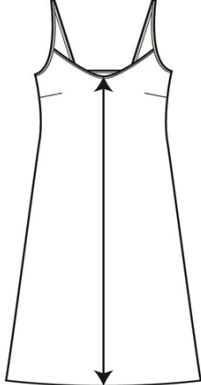
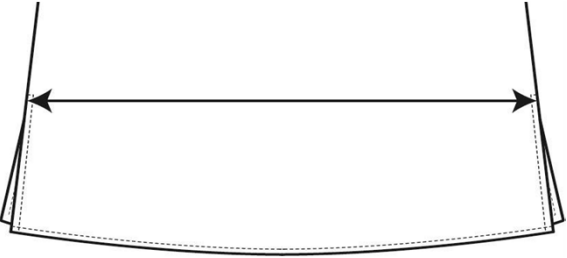
TRAVELSMITH OUTFITTERS: How To Measure

POM	Point of Measure	How To Measure Text	How To Measure Image
T275	Body Length From Center Front Top Edge (Tops)	On front of garment, measure from center front top edge straight down to bottom edge of garment.	
T276	Body Length From center Front Top Edge (Dresses)	On front of garment, measure from center front top edge straight down to the bottom edge of garment.	
T330	Sweep - at Top of Vents	Measure straight across at top of vent or slits from edge to edge.	
T331	Sweep - Straight Edge to Edge	Measure straight across bottom from edge to edge.	

TRAVELSMITH OUTFITTERS: How To Measure

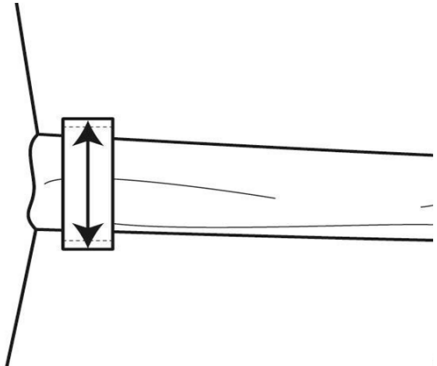
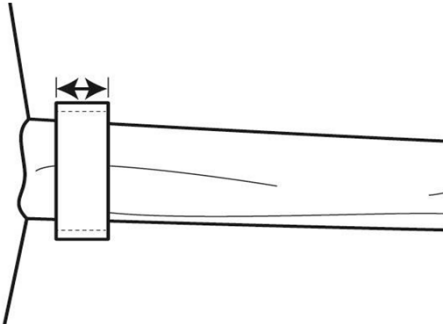
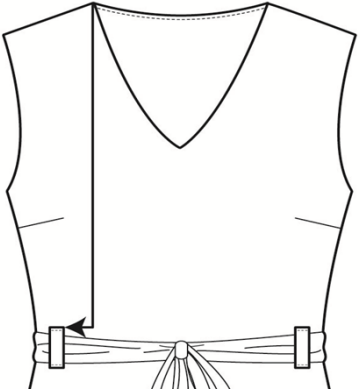
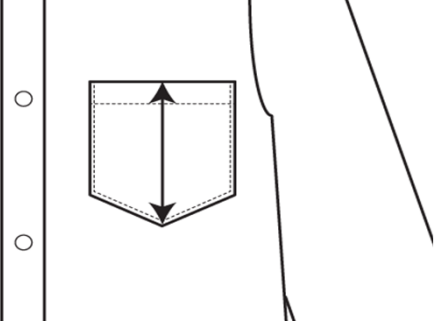
POM	Point of Measure	How To Measure Text	How To Measure Image
T400	Belt Loop Length	Measure belt loop straight down from edge to edge along center.	
T401	Belt Loop Width	Measure belt loop straight across from edge to edge.	
T405	Belt Loop Placement - From HPS	From HPS (High Point of Shoulder), measure straight down and across to the top of the belt loop.	
T420	Chest Pocket Height Center	Measure at center of pocket straight from top edge to bottom edge.	

TRAVELSMITH OUTFITTERS: How To Measure

POM	Point of Measure	How To Measure Text	How To Measure Image
T421	Chest Pocket Height Side	Measure at side edge of pocket from top edge to bottom.	
T422	Chest Pocket Width Bottom	Measure straight across bottom of pocket from edge to edge.	
T423	Chest Pocket Width Top	Measure straight from top edge of pocket to side seam.	
T425	Chest Welt Pocket Height	Measure from top of welt to seam.	

TRAVELSMITH OUTFITTERS: How To Measure

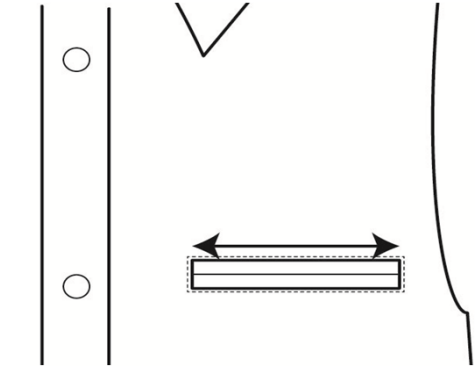
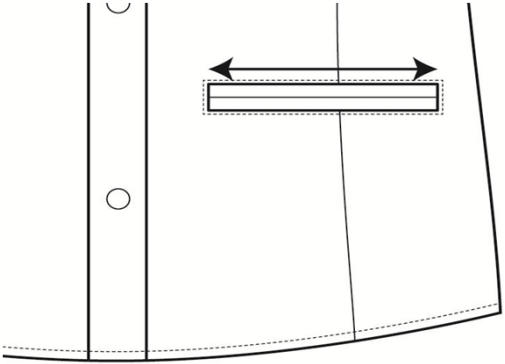
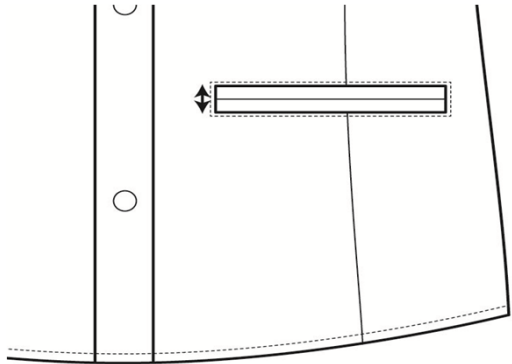
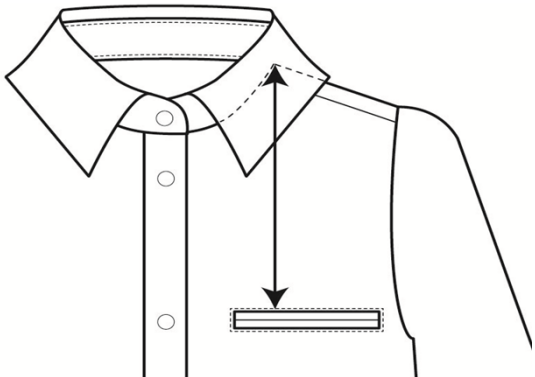
POM	Point of Measure	How To Measure Text	How To Measure Image
T426	Chest Welt Pocket length	Measure from edge to edge at top of welt.	
T450	Lower Welt Pocket Length - (Tops)	Measure from edge to edge at top of welt.	
T451	Lower Welt Pocket Height - (Tops)	Measure from top of welt to seam.	
T452	Chest Welt Pocket Position from HPS Tops	Measure from HPS (High Point of Shoulder) to top edge of welt.	

TRAVELSMITH OUTFITTERS: How To Measure

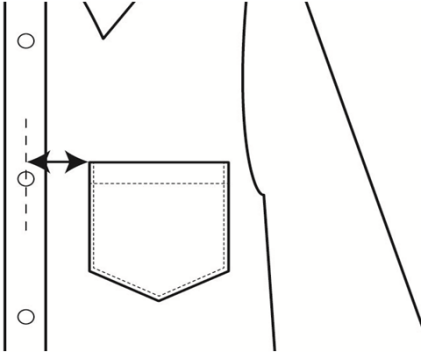
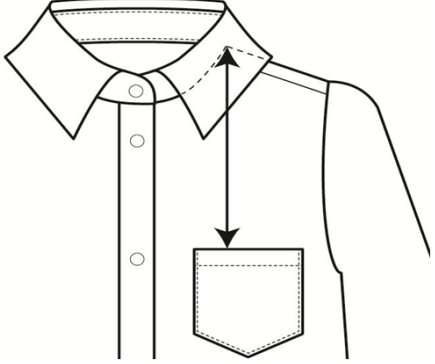
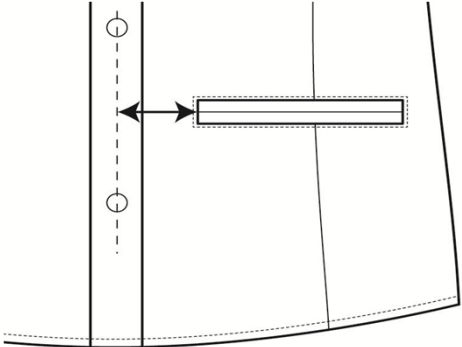
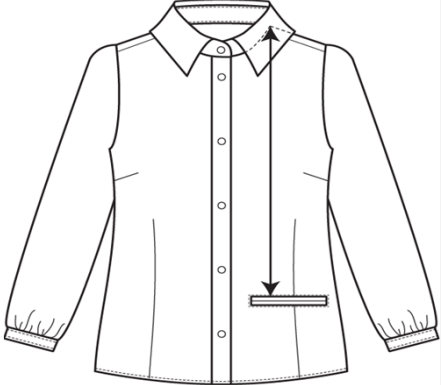
POM	Point of Measure	How To Measure Text	How To Measure Image
T460	Chest Pocket Placement - From CF	Measure from CF to pocket edge.	 <p>The diagram shows a partial view of a shirt's chest area. A vertical dashed line represents the center front (CF). A horizontal double-headed arrow indicates the distance from this line to the left edge of a chest pocket. The pocket is shown as a trapezoidal shape with a pointed bottom.</p>
T461	Chest Pocket Placement - From HPS	Measure from HPS (High Point of Shoulder) to top edge of pocket.	 <p>The diagram shows a full view of a shirt's upper torso. A vertical double-headed arrow starts at the high point of the shoulder (HPS) and extends down to the top edge of a chest pocket. The pocket is shown as a trapezoidal shape with a pointed bottom.</p>
T465	Lower Pocket Placement - From CF	Measure from CF to pocket edge.	 <p>The diagram shows a partial view of a shirt's lower chest area. A vertical dashed line represents the center front (CF). A horizontal double-headed arrow indicates the distance from this line to the left edge of a lower chest pocket. The pocket is shown as a simple rectangular shape.</p>
T466	Lower Pocket Placement - From HPS	Measure from HPS (High Point of Shoulder) to top edge of pocket.	 <p>The diagram shows a full view of a long-sleeved shirt. A vertical double-headed arrow starts at the high point of the shoulder (HPS) and extends down to the top edge of a lower chest pocket. The pocket is shown as a simple rectangular shape.</p>

TRAVELSMITH OUTFITTERS: How To Measure

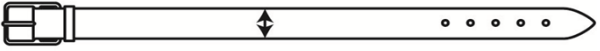
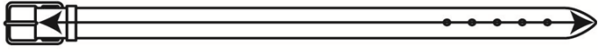
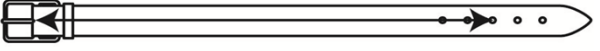
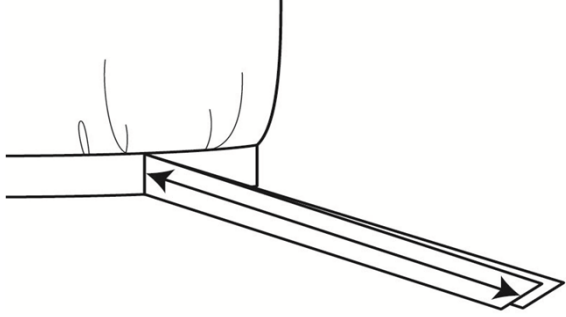
<u>POM</u>	<u>Point of Measure</u>	<u>How To Measure Text</u>	<u>How To Measure Image</u>
T490	Belt Width	Measure belt width from edge to edge	
T491	Belt Length - total	Measure Belt Length From fold to end along center of belt.	
T492	Belt Length from Buckle to 3rd Grommet - circumference	Measure belt length from fold to center of 3rd grommet along center of belt.	
T495	Tie Length	Measure tie length from body seam to tie edge.	

TRAVELSMITH OUTFITTERS: How To Measure

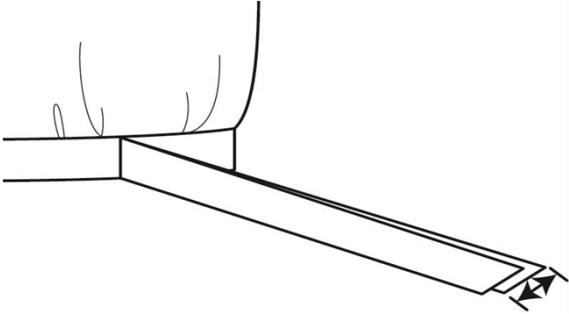
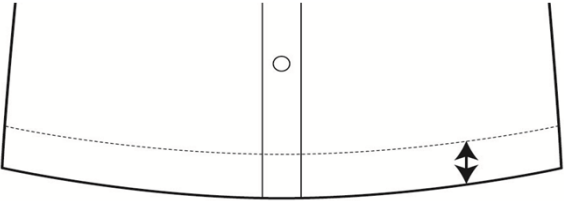
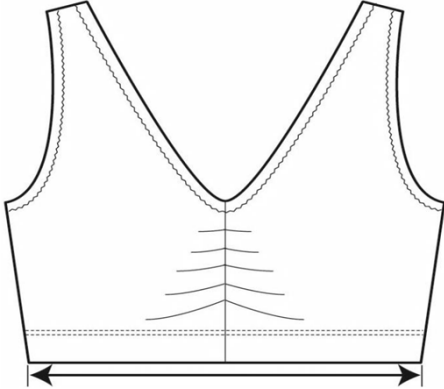
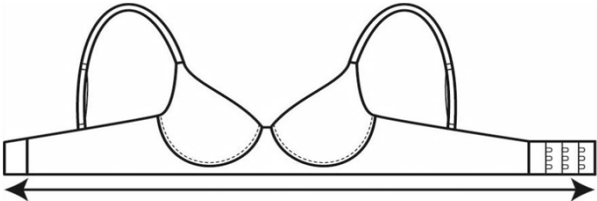
POM	Point of Measure	How To Measure Text	How To Measure Image
T496	Tie Width	Measure tie width from edge to edge.	
T500	Hem Height	Measure from stitch line to edge of garment.	
T601	Bra Girth (Pullover Styles)	Measure straight across the bottom of the bra from inside edge to inside edge. Double measurement.	
T602	Bra Girth (Fastening Styles)	Lay garment flat. Measure straight across along bottom from end to end without stretching.	

TRAVELSMITH OUTFITTERS: How To Measure

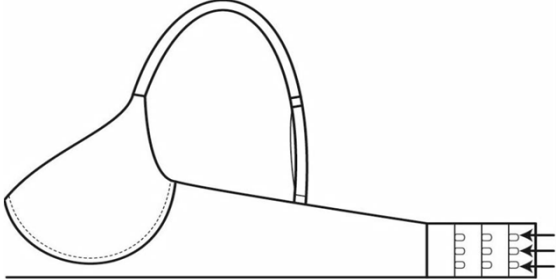
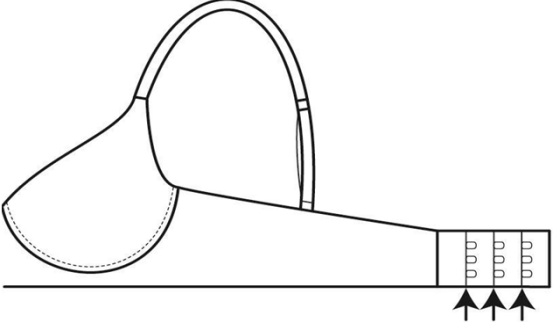
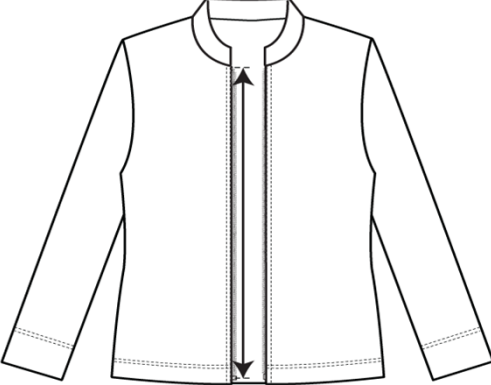
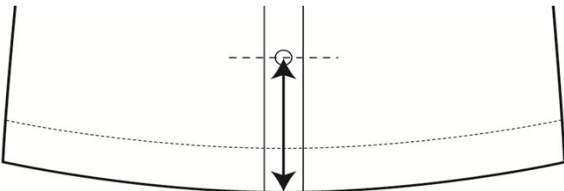
POM	Point of Measure	How To Measure Text	How To Measure Image
T605	Bra - # of Closures	Number of hooks counted vertically in one row.	
T606	Bra - # of Positions	Number of hook rows counted horizontally.	
T900	Zipper Opening - Functional	Measure from the top stop to bottom of zipper stop.	
T905	Button/Snap Placement from Bottom Edge	Measure from center of last button to bottom edge of garment.	

TRAVELSMITH OUTFITTERS: How To Measure

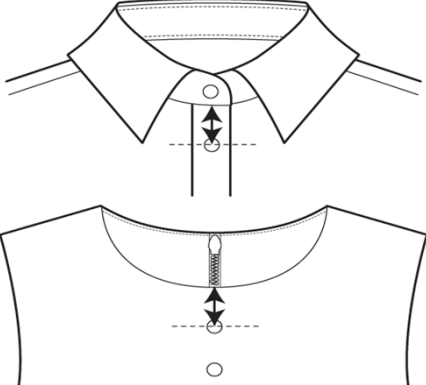
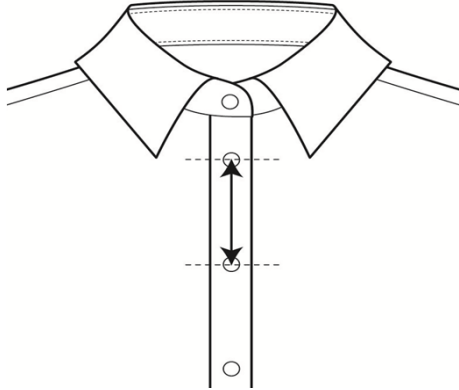
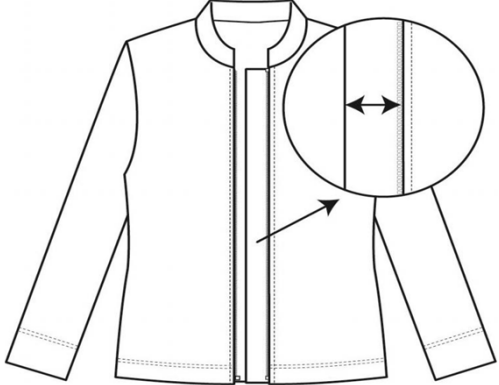
POM	Point of Measure	How To Measure Text	How To Measure Image
T906	Button/Snap Placement from Top Edge or Seam	Measure from top edge or neck seam straight down to center of button.	
T907	Button Spacing	Measure center of button to center of next button.	
T910	Wind Guard Width	Measure windguard width from seam to edge.	
T911	Wind Guard Length	measure windguard length from edge to edge	